



All IBO examination questions are published under the following Creative Commons license:



CC BY-NC-SA (Attribution-NonCommercial-ShareAlike) - <https://creativecommons.org/licenses/by-nc-sa/4.0/>

The exam papers can be used freely for educational purposes as long as IBO is credited and new creations are licensed under identical terms. No commercial use is allowed.

4.3.2. Theoretical Test - Part B

CELL BIOLOGY

1. Deleted

2. Deleted

3. Deleted

4. In the left column below, you can see some proteins and in the right one there are some protein functions (1 – 8). Match the functions with the proteins by writing their numbers in the blanks. (A protein may have more than one function) (7 points).

___ Dynein	1. Shows channel protein characteristics
___ Na ⁺ -K ⁺ -	2. Possesses ATPase activity
___ Nexin	3. Facilitates transport through membrane
___ Connexon	4. Transport protein
___ Porin	5. Ion transport protein
___ Keratin	6. Attaches the microtubules
___ Desmin	7. Attaches Z bands to the myofibers in muscle
	8. Exists in the cytoskeleton of epithel cells

5.

A) (5') A G C C T A A T G G C C T A (3')

B) (3') T C G G A T T A C C G G A T (5')

The DNA above is replicated in the direction of the arrow. Write the appropriate letter showing the templates for leading strand and lagging strand synthesis in the blanks. (2 points)

template for the lagging strand _____

template for the leading strand _____

6.

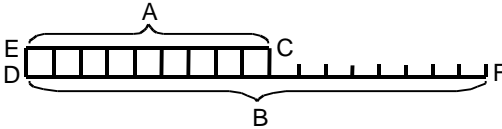

A suitable substrate for DNA polymerase is shown above. Fill in each blank below with a corresponding letter on the diagram. (3 points).

- Primer _____
- Template _____
- 3' end of the primer _____
- 5' end of the primer _____
- 3' end of the template strand _____
- 5' end of the template strand _____

7. Two molecules of DNA (I and II) are the same size (1000 bp) but differ in base composition. The first one contains 42% and the second one 66% A+T. (1.5 points).

A) How many G residues are there in DNA I and II? (1 point).

I: _____

II: _____

B) Which molecule (I or II) has a higher T_m . (T_m =dissociation point) (0.5 point)

8. Match the enzymes involved in the procaryotic replication at the left with their function at the right by putting the appropriate numbers in the blanks. (3 points).

DNA Helicase_____	1. Synthesis of RNA primers in the replication of the lagging strand
Primase_____	2. Unbinds double stranded DNA
DNA polymerase I 3'→5' exonuclease activity_____	3. Removes RNA primers.
DNA Ligase_____	4. Seals nicks in the DNA at the boundaries between Okazaki fragments.
Topoisomerase II_____	5. Removes mismatched bases
DNA Polymerase I 5'→3' exonuclease activity_____	6. Releases the topological stress produced by the unwinding of double stranded DNA.

9. Below is a diagram that shows DNA replication. On the diagram, mark: (5.4 points).

A) 3' ends with the letter "a" and 5' ends with the letter "b", (2 points).

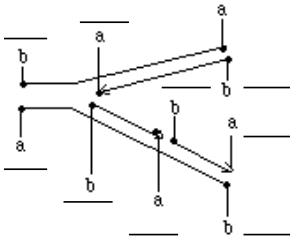

B) The lagging strand with letter "A", the leading strand with letter "B", Okazaki Fragments with letter "C", and RNA primers with letter "D". (1.4 points).

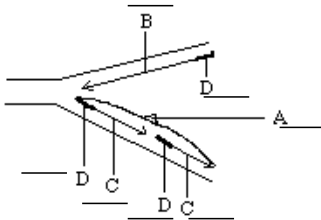

C) Match the enzymes with the reaction it catalyzes. Put the letter in front of the enzyme in the appropriate blanks below. (2 points).

- E. Primase
- F. Ligase
- G. DNA Polymerase II
- H. DNA Polymerase III
- I. DNA Polymerase I

- Enzyme _____ catalyzes the synthesis of fragment I
- Enzyme _____ catalyzes the synthesis of fragment II
- Enzyme _____ catalyzes the synthesis of RNA primer
- Enzyme _____ seals the nick shown as III in the diagram

- 10. Compare RNA polymerase with DNA polymerase III that function in the transcription and replication processes in *E. coli* on the basis of the parameters (A-H) with their characteristics given in the table. Put the letters in the appropriate boxes. (5 points).**

A) Promotor B) Origin C) 3'→5' D) 5'→3'
 E) dNTP F) NTP G) Yes (+) H) No (-)

	RNA Polymerase	DNA Polymerase III
The DNA region initially recognized and bound by the polymerase		
The direction of the polymerization		
The direction of enzyme movement on the template strand		
The type of the nucleotide substrates added to the growing chain		
3'→5' exonuclease activity (Proof reading ability)		

11. Deleted

12. Deleted

13. For each of the following statements, indicate with a “P” if the statement applies only to prokaryotes, with an “E” if the statement applies only to eukaryotes, and with an “E-P” if the statement applies to both eukaryotes and prokaryotes. (2.7 points).

- ___ A single RNA polymerase transcribes genes that encode mRNA, tRNA and rRNA.
- ___ Polymerisation of DNA is in the 5' → 3' direction.
- ___ Sigma (σ) subunit detaches from RNA polymerase shortly after transcription has initiated
- ___ The 5' end of the mature mRNA begins with a triphosphate
- ___ Polymerisation of RNA is in the 5' → 3' direction
- ___ They carry circular DNA
- ___ There are no introns in mRNA

14. The template strand for mRNA is given below. (5 points).

(5') CTT TGA TAA GGA TAG CCC TIC* (3')

A) What is the base sequence of the mRNA that can be transcribed from this strand?

B) Using the genetic code table given on the next page, write the amino acid sequence of the polypeptide coded by this mRNA.

C) Suppose the other (complementary) strand is used as a template for the transcription. What is the amino acid sequence of the resulting peptide?

D) If the labeled base above in the template strand is converted to “A” instead of “T”, what would be the type of the mutation? Transition (X), transversion (Y), deletion (Z) or insertion (W) Write the correct letter on the line below.

E) What is the type of this mutation? Neutral (N), silent (S), missense(M), or nonsense (NS)? Write the correct letter on the line below.

Report of the 11th IBO in Antalya

BASE I	U		C		A		G		BASE II
U	UUU	phe	UCU	ser	UAU	tyr	UGU	cys	U
U	UUC	phe	UCC	ser	UAC	tyr	UGC	cys	C
U	UUA	leu	UCA	ser	UAA	stop	UGA	stop	A
U	UUG	leu	UCG	ser	UAG	stop	UGG	trp	G
C	CUU	leu	CCU	pro	CAU	his	CGU	arg	U
C	CUC	leu	CCC	pro	CAC	his	CGC	arg	C
C	CUA	leu	CCA	pro	CAA	gin	CGA	arg	A
C	CUG	leu	CCG	pro	CAG	gin	CGG	arg	G
A	AUU	ile	ACU	thr	AAU	asn	AGU	ser	U
A	AUC	ile	ACC	thr	AAC	asn	AGC	ser	C
A	AUA	ile	ACA	thr	AAA	lys	AGA	arg	A
A	AUG	met	ACG	thr	AAG	lys	AGG	arg	G
G	GUU	val	GCU	ala	GAU	asn	GGU	gly	U
G	GUC	val	GCC	ala	GAC	asp	GGC	gly	C
G	GUA	val	GCA	ala	GAA	glu	GGA	gly	A
G	GUG	val	GCG	ala	GAG	glu	GGG	gly	G

15. Deleted

16. Deleted

17.

- A) The heart muscle while working aerobically
- B) A bacterium culture that cannot grow in the dark
- C) A propionic acid bacteria that can grow under anaerobic conditions in the dark
- D) Erythrocytes

Fill in the blanks with the suitable letters above.(2 points)

- _____ provides ATP requirement by photosynthesis
- _____ provides ATP requirement by converting glucose to lactate
- _____ provides ATP requirement by fermentation
- _____ provides ATP requirement by oxidative phosphorylation

18. Atmospheric nitrogen (N_2) is chemically very stable. Only a few prokaryotic species can convert atmospheric nitrogen into usable form by plants. One of the characteristics of these organisms is that they possess the nitrogenase enzyme complex that can fix the nitrogen. O_2 irreversibly inhibits this enzyme. Considering that we live in an oxidizing environment, nitrogen fixing organisms must have a variety of mechanisms for protection from O_2 .

A) Below are given some characteristics of bacteria. Put an “ X ” in the blank for the ones that can fix nitrogen. (4 points).

- _____ A free living bacterium under soil like Clostridium
- _____ Cyanobacteria like *Nostoc muscorum* possess thick cell walls
- _____ Bacteria like E.coli that are inhabitants of the intestinal tract
- _____ Symbiotic bacteria like Rhizobium of leguminous plants that possess specialized protein leghemoglobin
- _____ High mutation rate bacteria like Salmonella typhimurium

B) Which is the major product of the nitrogenase enzyme complex? (Mark with an “X”)

- _____ ammonia _____ nitrite _____ nitrate _____ nitrogen gas

GENETICS AND EVOLUTION

19. Consider cases of unknown paternity where the ABO blood group phenotype of concerned individuals is to be used to help identify fathers. The frequency of blood group alleles in the population is as follows: $p(A) = 0.2$, $p(B) = 0.3$, $p(O) = 0.5$. Blood group assessments are made by routine laboratory procedures, which can assess blood group *phenotypes*. (4 points)

a. In a case where the mother's blood group is A and the child's blood group is AB, what is the probability that a man chosen at random from the population will be proven not to have fathered the child purely on the basis of his blood group. (2 points)

Answer: _____

b. In a case where the mother's blood group is A and the child's blood group is O, what is the probability that a man chosen randomly from the population will be proven not to have fathered the child purely on the basis of his blood group. (2 points)

Answer: _____

20. In a certain human population 64% is able to roll their tongue.

This ability is based on a dominant allele.

A roller marries a non-roller.

Calculate the chance of having a roller baby. (4 points)

Answer: _____ %

21. Deleted

22. In peas, the allele for green seed color (A) is dominant over the allele for yellow seed color (a) and the allele for normal leaf (B) is dominant over the allele for rolled leaf (b). The F₁ generation is obtained by crossing AABB x aabb. When these F₁ plants are tested again, the following results are found;

117 green seed / normal leaf

115 yellow seed / rolled leaf

76 green seed / rolled leaf

80 yellow seed / normal leaf

$$\chi^2 = \sum [(O-E)^2 / E]$$

O: Observed value

E: Expected value (6 points)

A) Degree of freedom: _____

B) Calculate the χ^2 value and check from the table: _____

C) According to the result of choice B, decide whether these genes are linked or not (mark with the letter "X")

Genes are linked: _____

Genes are not linked: _____

D) If these genes are linked, calculate the distance between the genes

The distance between the genes is _____ map units

23. (2.5 points).

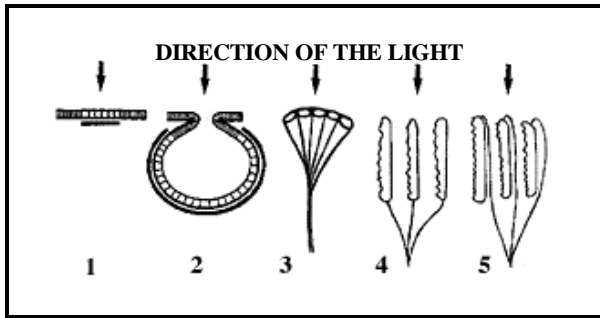

According to the structure and the location of the light sensors illustrated on the scheme above, match the followings

Animal group

_____ Earthworm

_____ Squid

_____ Human being

_____ Insect

_____ Planaria

PLANT ANATOMY AND PHYSIOLOGY

24. (2 points)

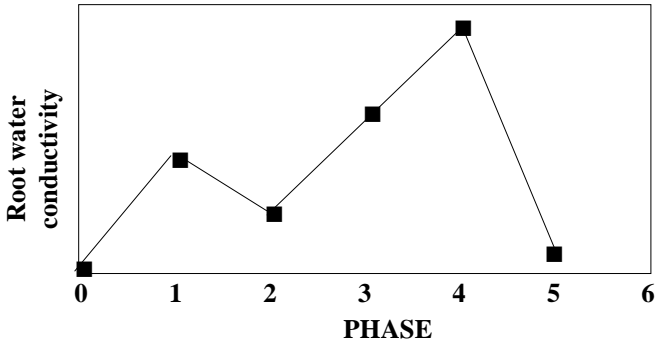

The graph represents the water conductivity of a root. Mark the true alternative(s) with an “X”.

- A) The temperature decreases between the phases 1-2 and 4-5
- B) CN^- is added to the medium between the phases 0-1 and 2-4
- C) There is enough oxygen between the phases 1-2 and 4-5
- D) The root cannot get enough nutrient between the phases 1-2 and 4-5

25. (3.6 points)

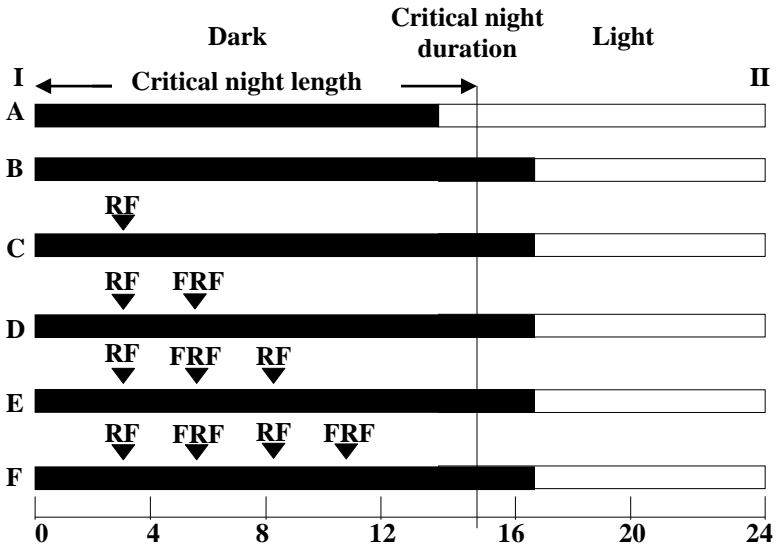

RF : red or white flash

FRF: far red flash

The figure represents exposure of long-day and short-day plants to a variety of light regimes. Decide whether long-day (short-night) and short-day (long-night) plants will flower (+) or not (-) under the conditions given above.

	Long day (short-night) plant	Short-day (long-night) plant
A)		
B)		
C)		
D)		
E)		
F)		

I

II

26. Deleted

27. Deleted

28. Deleted

29. Deleted

30. Label the figure using the numbers (2.1 points)

01 Anther	05 Phyllary
02 Ovarium	06 Nectar
03 Stigma	07 Pappus
04 Corolla	

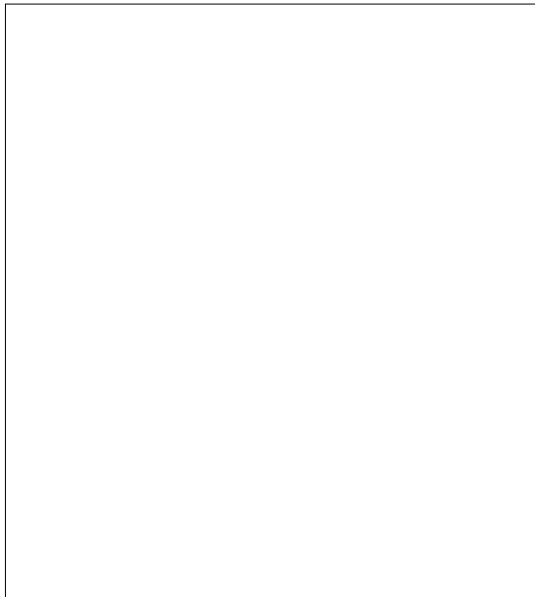

31. A student is studying a tundra plant at different temperatures.

He investigates:

**The production of oxygen by means of photosynthesis, and
The net amount of oxygen released into the environment**

**The diagram shows the results. It is up to you to decide which
curve is production and which curve is release. (2 points)**

oxygen production & release
of a tundra plant

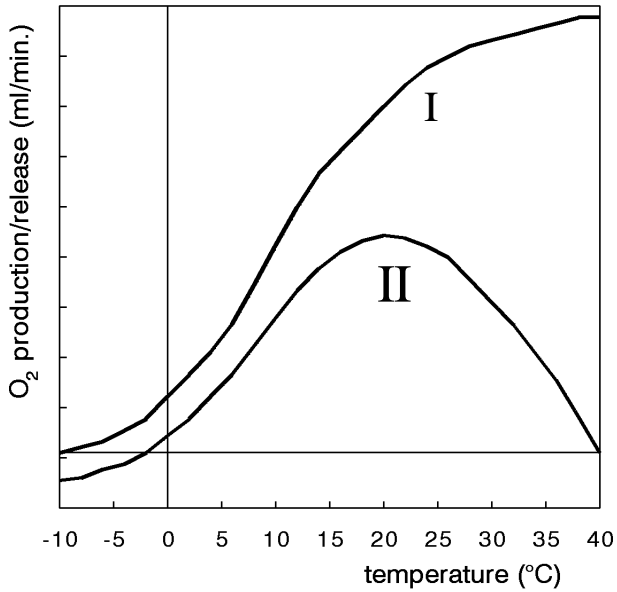

Now answer the following two questions:

31.1. At which temperature(s) are both the ATP-production and the ATP-consumption approximately equal? (1 point)

- A) At 20 °C
- B) At -2,5 °C and at +40 °C
- C) Only in between -10 °C and -2,5 °C
- D) Only in between -10 °C and + 10 °C
- E) In between -10 °C and + 40 °C

31.2. At which temperature(s) are the production of oxygen by photosynthesis and the consumption of oxygen by dissimilation equal to each other? (1 point)

- A) At 20 °C
- B) At -2,5 °C and at +40 °C
- C) Only in between -10 °C and -2,5 °C
- D) Only in between -10 °C and + 10 °C
- E) In between -10 °C and + 40 °C

32. Select numbers from the answer key and mark the parts of the different fruit types (3 points)

Answer key:

- 1- Remains of sepals
- 2- Receptacle
- 3- Seed
- 4- Placenta
- 5- Pedicel

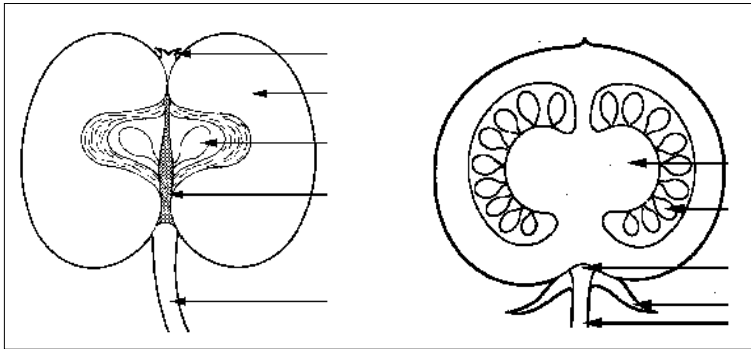

33. Deleted

34. Deleted

Theoretical Test - Part B

35. Which of the following can be expected to happen when glucose is added to the mineral solution in which plant cells are bathed. Put a cross (X) in the related boxes.

35. 1. (1 point)

	Increases	Decreases
Membrane potential		
pH of the medium		

35. 2 (1 point)

	Taken up	Not taken up
Glucose		

BIOSYSTEMATICS

36. Deleted

37. Deleted

38. Which of the following descriptions about vertebrates is/are correct? Mark the correct ones with an "X". (2.5 points)

- _____ The scales of fish are epidermal scales
- _____ The scales of snakes are epidermal scales
- _____ The scales of lizards are epidermal scales
- _____ The scales of pangolins are epidermal scales
- _____ The hairs of humans are derivatives of epidermis
- _____ The horns of deers are epidermal in origin
- _____ The horns of cattles are epidermal in origin
- _____ The horns of rhinoceros are epidermal in origin

39. Deleted

40. Deleted

41. I. Rhynia II. Spirogyra III. Rhizopus/Mucor
 IV. Lycopodium V. Equisetum

Establish the relationships between the given genera names above with the terms below (You can use any term more than once.) (3.6 points).

- _____ It appeared in the Carboniferous period
- _____ The sporangia are generally cluster shaped
- _____ The zoospores never appear
- _____ The oldest plant that has no leaves
- _____ The first real roots are seen in this group
- _____ The prothallus_reaches sexual maturity in 12-15 year's time
- _____ The chloroplasts are helozonic (spiral shaped)
- _____ Xylem is made of ringed and spiral tracheids
- _____ In the cross section, the xylem appears star or plate shaped

42. Deleted

ANIMAL ANATOMY AND PHYSIOLOGY

43. Some animals and some of their characteristics are shown in the table . Match these characteristics correctly with the given animals (mark the appropriate box with an "X") (3.6 points).

	Fresh water fish (carp)	Bird (pigeon)	Marine fish (sea bass)	Lizard (Chameleon)	Marine mammal (whale)	Terrestrial mammal (Mouse)
Drinks water regularly						
Does not drink water						
Wastes are discarded as ammonia						
Wastes are discarded as urea						
Wastes are discarded as uric acid						
Actively secretes salt						
Actively absorbs salt						
Excretes hipotonic urine relative to the body fluids						
Excretes isotonic urine relative to the body fluids						
Excretes hipertonc urine relative to the body fluids						

44.

In the figure, some parts of a mammalian nephron are numbered (I-V). Match these numbers with the events or properties given in the table (a number can be used more than once). (2.5 points).

Cl ⁻ is actively pumped out	
Blood is filtered	
Almost all glucose is reabsorbed	
Urine becomes acidic	
Na ⁺ is reabsorbed under aldosterone control	

45. In humans, some mechanisms are activated in the case of a serious decrease in the red blood cell count. Some sources (organs/tissues), secreted substances, targets and biological responses are given in the list (1-13). Examine them and put appropriate numbers in the appropriate boxes in the table. (2 points).

- 1. Liver**
- 2. Kidneys**
- 3. Heart**
- 4. Erythropoietin**
- 5. Lungs**
- 6. Spleen**
- 7. Bone marrow**
- 8. Antidiuretic hormone**
- 9. Renin**
- 10. Androgens**
- 11. Adrenaline**
- 12. Increase in erythropoiesis**
- 13. Increase in the blood glucose level**

Stimulus	Stimulated organ/tissue	Secreted Substance	Target	Biological Response
Decreased red blood cell count				

46. Deleted

- 47. In the figure, 4 parameters varying according to the different parts of the human circulation system (aorta, arteries, arterioles, capillaries, venules, veins, and vena cava) are plotted (I-IV). Match the numbers of the curves with the parts of the circulation system (Put the appropriate number in front of each part.). (2 points).**

_____ Total cross-sectional area

_____ Blood pressure

_____ Blood velocity

_____ Vessel diameter

48. Inspect the following scheme representing the blood circulation of a human embryo just before birth. The numbers represent the blood flow in ml/min per kg body mass of the embryo. (2 points).

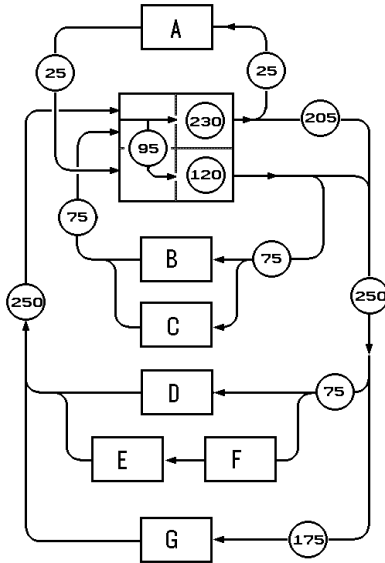

48. 1. Indicate the letter of the box which represents the placenta. (1 point).

Answer: _____ (fill in a letter)

48. 2. Calculate the ratio of blood flow through the lungs just before and few days after the birth, assuming that the total amount of blood leaving the heart at both are equal. (1 point).

Answer: (Ratio) Before / After = _____

- 49. In the human circulation various mechanisms are activated when blood pressure decreases below or rises above its normal level. This question is related to a situation where the blood pressure exceeds its normal level. Indicate the events that take place at various parts of the circulation system to return the pressure back to its normal level by marking the appropriate boxes in the table with an "X" .(3 points).**

Stretch receptors		Cardioacceleratory center		Cardioinhibitory center		Vasomotor center	
stimulated	inhibited	stimulated	inhibited	stimulated	inhibited	stimulated	inhibited

Cardiac output		Arterioles	
increases	decreases	constricted	dilated

- 50. Deleted**

51.

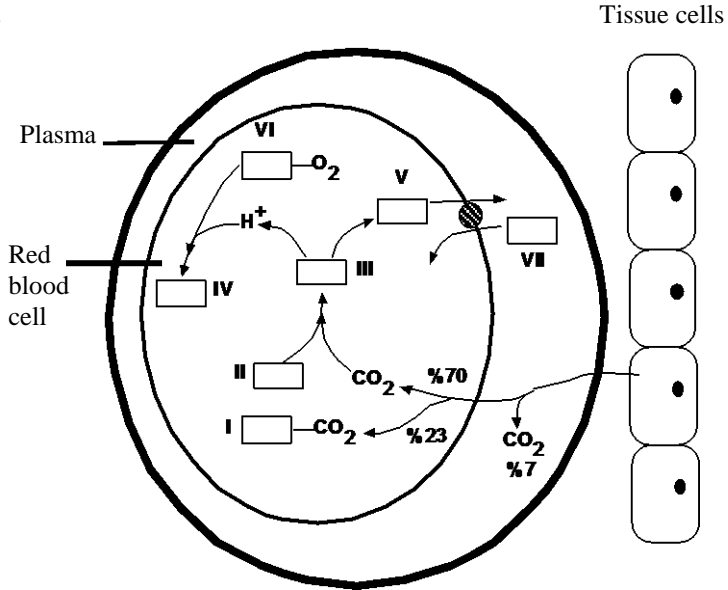

The figure shows the reactions occurring during gas and electrolyte exchange between blood capillaries loaded with O₂ and the tissue cells. Fill in the empty boxes in the figure and below with the appropriate numbers out of the 13 substances given below. (3.5 points).

- | | | |
|-----------------------------------|-----------------------------------|----------------------|
| 1. Hb (hemoglobin) | 6. H ₂ PO ₄ | 11. HCO ₃ |
| 2. H ₂ CO ₃ | 7. H ₂ SO ₄ | 12. HbO ₂ |
| 3. H ₂ O | 8. Cl ⁻ | 13. HHb |
| 4. CO ₂ | 9. Na ⁺ | |
| 5. NaHCO ₃ | 10. Ca ²⁺ | |

I	II	III	IV	V	VI	VII

52. The respiratory quotient RQ of an organism is defined as

$$\text{RQ} = \text{CO}_2 \text{ (produced)} / \text{O}_2 \text{ (used)(in a given time)}$$

The theoretical RQ values of important substrates are approximately:

substrate (completely oxidised)	RQ
Carbohydrate	1,0
Fat	0,7
Protein	0,9

In practice, the values of RQ will be higher or lower than the theoretical ones.

What is the effect of the following circumstances on RQ? (2 points).

Put an “X” in the correct boxes in the following table.

	RQ higher	RQ lower
Anaerobic respiration of substrate		
Incomplete oxidation of substrate		
Fixation of CO ₂ as CaCO ₃		
Converting carbohydrate into fat		

53. Figure shows 5 saturation curves of O₂ with hemoglobin each obtained from a different animal (I-V). The shape of these curves differ according to the basal metabolism of the animal. Match these curves with the animals given below (Put the number of the curve in front of the name of the animal.) (2.5 points).

_____ Elephant

_____ Snake

_____ Bird (sparrow)

_____ Man

_____ Mouse

54. Mark the correct change in the arterial chemoreceptors, respiratory rate, H⁺ excretion rate in the kidneys and blood partial CO₂ pressure that takes place in order to correct a drop in blood pH. (2 points).

Arterial chemoreceptors		Respiratory rate	
stimulation	inhibition	increase	decrease

H ⁺ excretion in the kidneys		Blood partial CO ₂ pressure	
increase	decrease	increase	decrease

55. Write the numbers which refer to the extra-embryonic membranes amnion (1), allantois (2), yolk-sac (3) and chorion (4) that are seen during the development of organisms given below. (1.4 points)

Fish _____
 Frog _____
 Reptile _____
 Bird _____
 Mammal _____

56. The following statements are about calcium and its regulation in humans. Match correctly the substances given in the answer key with the statements (put the letter of the substance in front of the statements). (2 points).

_____ It is the vitamin which promotes the accumulation of calcium in the body

_____ It is the gland which secretes calcitonin, the hormone causes calcium accumulation

_____ It is the the place where calcium accumulates in great amounts in the body

_____ It is the gland which secretes hormone that increases the calcium level in the blood

Answer key:

A. Vitamin D

B. Bones

C. Thyroid

D. Blood

E. Parathyroid gland

F. Vitamin C

G. Adrenal gland

57. Some human endocrine and exocrine glands are numbered in the figure . In the following statements some functions related to these glands are given. Match the statements with the glands in the figure (Put the number of the gland in front of the statements). (3 points)

- _____ It secretes a hormone which increases the reabsorption of Na^+ into the blood
- _____ Its secretion is increased when blood Ca^{2+} concentration drops below its normal level
- _____ If its secretion is decreased the basal metabolic rate also decreases
- _____ Its secretion is necessary for the development of cellular immunity
- _____ Its hormone induces red blood cell production in bone marrow
- _____ Without its hormone, there will be an excessive water loss from the body
- _____ Its secretion is increased after a carbohydrate rich meal
- _____ Acidic compounds stimulate its hormone secretion
- _____ Its secretion is necessary for the chemical breakdown of proteins

58. Deleted

59. Deleted

60. Deleted

ECOLOGY

61. Deleted

62. A food web including 6 different species (A to F) in an ecosystem is shown in the figure illustrated below. The arrows refer to the energy flow directions. Match the following according to that figure. (3.5 points).

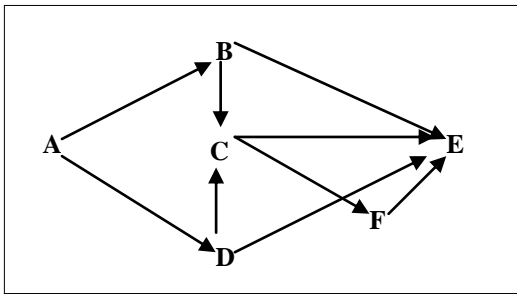

- Producer species _____
- Decomposer species _____
- Consumer species on the first trophic level _____
- Consumer species on the second trophic level _____
- Consumer species on the third trophic level _____
- The species in which biomagnification is seen at the highest level _____

- 63. Age distribution in human populations can be shown in three different types as developing type, stable type and regression type. Mark the stable type age distribution among the following figures. (1 point).**

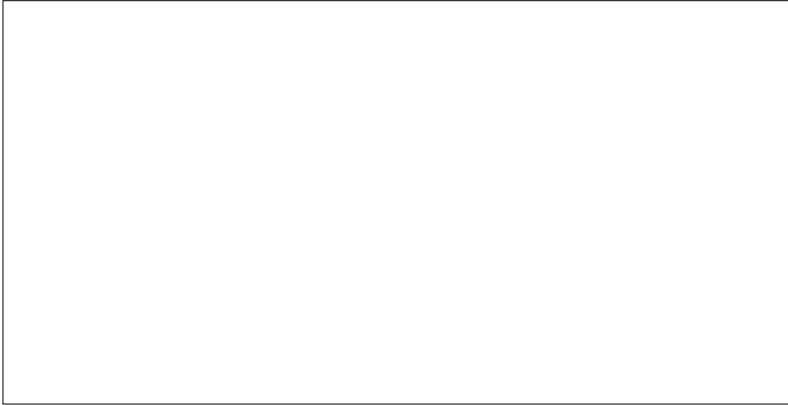

64. In the tables below, one might see the relationships among the populations and the results of these influences. Mark the correct answer(s) by an ellipse in each box. For clarity, an example has been given for competition. (3.5 points).

<p style="text-align: center;">Competition</p> <table style="width: 100%; border-collapse: collapse;"> <thead> <tr> <th colspan="2" style="text-align: center;"><u>Species</u></th> </tr> <tr> <th style="text-align: center;">A</th> <th style="text-align: center;">B</th> </tr> </thead> <tbody> <tr><td style="text-align: center;">-</td><td style="text-align: center;">-</td></tr> <tr><td style="text-align: center;">+</td><td style="text-align: center;">-</td></tr> <tr><td style="text-align: center;">0</td><td style="text-align: center;">0</td></tr> <tr><td style="text-align: center;">+</td><td style="text-align: center;">+</td></tr> <tr><td style="text-align: center;">+</td><td style="text-align: center;">0</td></tr> <tr><td style="text-align: center;">-</td><td style="text-align: center;">0</td></tr> </tbody> </table>	<u>Species</u>		A	B	-	-	+	-	0	0	+	+	+	0	-	0	<p style="text-align: center;">Predation</p> <table style="width: 100%; border-collapse: collapse;"> <thead> <tr> <th colspan="2" style="text-align: center;"><u>Species</u></th> </tr> <tr> <th style="text-align: center;">A</th> <th style="text-align: center;">B</th> </tr> </thead> <tbody> <tr><td style="text-align: center;">-</td><td style="text-align: center;">-</td></tr> <tr><td style="text-align: center;">+</td><td style="text-align: center;">-</td></tr> <tr><td style="text-align: center;">0</td><td style="text-align: center;">0</td></tr> <tr><td style="text-align: center;">+</td><td style="text-align: center;">+</td></tr> <tr><td style="text-align: center;">+</td><td style="text-align: center;">0</td></tr> <tr><td style="text-align: center;">-</td><td style="text-align: center;">0</td></tr> </tbody> </table>	<u>Species</u>		A	B	-	-	+	-	0	0	+	+	+	0	-	0	<p style="text-align: center;">Parasitism</p> <table style="width: 100%; border-collapse: collapse;"> <thead> <tr> <th colspan="2" style="text-align: center;"><u>Species</u></th> </tr> <tr> <th style="text-align: center;">A</th> <th style="text-align: center;">B</th> </tr> </thead> <tbody> <tr><td style="text-align: center;">-</td><td style="text-align: center;">-</td></tr> <tr><td style="text-align: center;">+</td><td style="text-align: center;">-</td></tr> <tr><td style="text-align: center;">0</td><td style="text-align: center;">0</td></tr> <tr><td style="text-align: center;">+</td><td style="text-align: center;">+</td></tr> <tr><td style="text-align: center;">+</td><td style="text-align: center;">0</td></tr> <tr><td style="text-align: center;">-</td><td style="text-align: center;">0</td></tr> </tbody> </table>	<u>Species</u>		A	B	-	-	+	-	0	0	+	+	+	0	-	0
<u>Species</u>																																																		
A	B																																																	
-	-																																																	
+	-																																																	
0	0																																																	
+	+																																																	
+	0																																																	
-	0																																																	
<u>Species</u>																																																		
A	B																																																	
-	-																																																	
+	-																																																	
0	0																																																	
+	+																																																	
+	0																																																	
-	0																																																	
<u>Species</u>																																																		
A	B																																																	
-	-																																																	
+	-																																																	
0	0																																																	
+	+																																																	
+	0																																																	
-	0																																																	
<p style="text-align: center;">Neutralism</p> <table style="width: 100%; border-collapse: collapse;"> <thead> <tr> <th colspan="2" style="text-align: center;"><u>Species</u></th> </tr> <tr> <th style="text-align: center;">A</th> <th style="text-align: center;">B</th> </tr> </thead> <tbody> <tr><td style="text-align: center;">-</td><td style="text-align: center;">-</td></tr> <tr><td style="text-align: center;">+</td><td style="text-align: center;">-</td></tr> <tr><td style="text-align: center;">0</td><td style="text-align: center;">0</td></tr> <tr><td style="text-align: center;">+</td><td style="text-align: center;">+</td></tr> <tr><td style="text-align: center;">+</td><td style="text-align: center;">0</td></tr> <tr><td style="text-align: center;">-</td><td style="text-align: center;">0</td></tr> </tbody> </table>	<u>Species</u>		A	B	-	-	+	-	0	0	+	+	+	0	-	0	<p style="text-align: center;">Mutualism</p> <table style="width: 100%; border-collapse: collapse;"> <thead> <tr> <th colspan="2" style="text-align: center;"><u>Species</u></th> </tr> <tr> <th style="text-align: center;">A</th> <th style="text-align: center;">B</th> </tr> </thead> <tbody> <tr><td style="text-align: center;">-</td><td style="text-align: center;">-</td></tr> <tr><td style="text-align: center;">+</td><td style="text-align: center;">-</td></tr> <tr><td style="text-align: center;">0</td><td style="text-align: center;">0</td></tr> <tr><td style="text-align: center;">+</td><td style="text-align: center;">+</td></tr> <tr><td style="text-align: center;">+</td><td style="text-align: center;">0</td></tr> <tr><td style="text-align: center;">-</td><td style="text-align: center;">0</td></tr> </tbody> </table>	<u>Species</u>		A	B	-	-	+	-	0	0	+	+	+	0	-	0	<p style="text-align: center;">Commensalism</p> <table style="width: 100%; border-collapse: collapse;"> <thead> <tr> <th colspan="2" style="text-align: center;"><u>Species</u></th> </tr> <tr> <th style="text-align: center;">A</th> <th style="text-align: center;">B</th> </tr> </thead> <tbody> <tr><td style="text-align: center;">-</td><td style="text-align: center;">-</td></tr> <tr><td style="text-align: center;">+</td><td style="text-align: center;">-</td></tr> <tr><td style="text-align: center;">0</td><td style="text-align: center;">0</td></tr> <tr><td style="text-align: center;">+</td><td style="text-align: center;">+</td></tr> <tr><td style="text-align: center;">+</td><td style="text-align: center;">0</td></tr> <tr><td style="text-align: center;">-</td><td style="text-align: center;">0</td></tr> </tbody> </table>	<u>Species</u>		A	B	-	-	+	-	0	0	+	+	+	0	-	0
<u>Species</u>																																																		
A	B																																																	
-	-																																																	
+	-																																																	
0	0																																																	
+	+																																																	
+	0																																																	
-	0																																																	
<u>Species</u>																																																		
A	B																																																	
-	-																																																	
+	-																																																	
0	0																																																	
+	+																																																	
+	0																																																	
-	0																																																	
<u>Species</u>																																																		
A	B																																																	
-	-																																																	
+	-																																																	
0	0																																																	
+	+																																																	
+	0																																																	
-	0																																																	
<p style="text-align: center;">Amensalism</p> <table style="width: 100%; border-collapse: collapse;"> <thead> <tr> <th colspan="2" style="text-align: center;"><u>Species</u></th> </tr> <tr> <th style="text-align: center;">A</th> <th style="text-align: center;">B</th> </tr> </thead> <tbody> <tr><td style="text-align: center;">-</td><td style="text-align: center;">-</td></tr> <tr><td style="text-align: center;">+</td><td style="text-align: center;">-</td></tr> <tr><td style="text-align: center;">0</td><td style="text-align: center;">0</td></tr> <tr><td style="text-align: center;">+</td><td style="text-align: center;">+</td></tr> <tr><td style="text-align: center;">+</td><td style="text-align: center;">0</td></tr> <tr><td style="text-align: center;">-</td><td style="text-align: center;">0</td></tr> </tbody> </table>			<u>Species</u>		A	B	-	-	+	-	0	0	+	+	+	0	-	0																																
<u>Species</u>																																																		
A	B																																																	
-	-																																																	
+	-																																																	
0	0																																																	
+	+																																																	
+	0																																																	
-	0																																																	

65. In the figure illustrated below the energy flow between the organisms on different trophic levels in a food web is shown. On the scheme given below, please fill in the blanks with the numbers given below for the producers, and 1^o, 2^o, 3^o trophic level consumers according to their levels. (3.6 points).

Producers _____

2^o consumers _____

1^o consumers _____

3^o consumers _____

66. Deleted

67. The figure given below represents the carbon cycle. Fill in the blanks with the suitable numbers that corresponds to the processes concerning the cycle given to you. (2 points).

Processes:

- Combustion _____
- Consumption _____
- Death _____
- Photosynthesis _____
- Respiration _____
- Decomposition _____

68. In the table, the principle components that form an aquatic ecosystem are given. Put the organisms, and components, in their places in the table given below. (2 points).

- I. Fungi**
- II. Phytoplankton**
- III. Inorganic components**
- IV. Zooplankton**

The part of the ecosystem	The organism or component
Abiotic substance	
Producer	
Consumer	
Decomposer	

69. Deleted

70. The density of a population that reaches equilibrium is known as the carrying capacity in that species for that habitat. When a population approaches the carrying capacity of any habitat, which of the following shows a tendency to increase? Mark all correct answers with an “X”. (2.5 points).

- _____ Competition for resources
- _____ Competition for shelters
- _____ Competition for mating areas
- _____ Immigration
- _____ Accumulation of toxic wastes

Theoretical Test - Part B

71. In any habitat that includes a predator species and its prey, it is known that both of their populations show linked fluctuations. Show the curve belonging to the predator species by putting an "X" in the circle. (1 point).

N 1

N 2

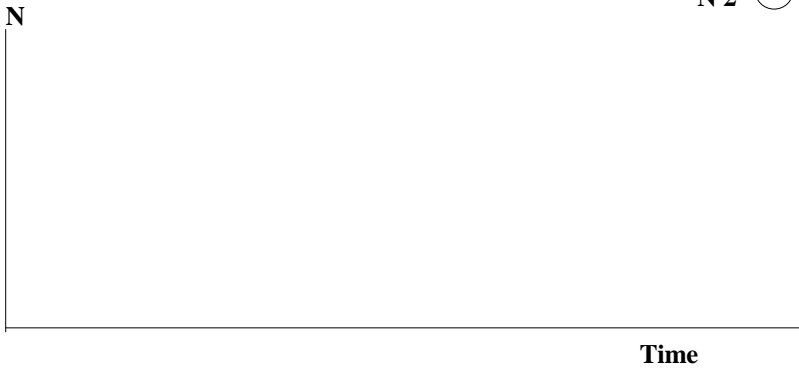

BEHAVIOUR

72. Thorleif Schjelderup- Ebbe reported the results of a study about the social organization carried out in a poultry yard with Leghorn hens . He found that there was a kind of order (arrangement) in the peck that was related with a real hierarchy in the group.

The following matrix shows the peck frequency within a group of 13 females (from A to M). Each datum indicates the times that the hen identified by the letter in the horizontal line is pecked by one in the vertical line. (4 points)

	M	L	K	J	I	H	G	F	E	D	C	B	A
A	53	45	38	51	35	36	41	29	33	34	41	39	-
B	42	34	37	28	36	29	40	46	43	53	47	-	-
C	36	29	26	44	31	38	24	42	37	32	-	-	-
D	35	27	39	29	36	52	43	31	26	-	-	-	-
E	48	30	27	43	41	40	36	35	-	-	-	-	-
F	43	39	42	40	39	33	31	-	-	-	-	-	-
G	39	38	28	36	41	39	-	-	-	-	-	-	-
H	35	52	47	-	37	-	-	-	-	-	-	-	-
I	37	41	42	54	-	-	-	-	-	-	-	-	-
J	33	29	31	-	-	32	-	-	-	-	-	-	-
K	42	37	-	-	-	-	-	-	-	-	-	-	-
L	39	-	-	-	-	-	-	-	-	-	-	-	-
M	-	-	-	-	-	-	-	-	-	-	-	-	-

72.1. Which of the following female has the highest hierarchy within the group? (2 points)

___A) A ___B) B ___C) J ___D) H ___E) M

72.2. Deleted

72.3. Deleted

72.4. Which ones of the following may be the advantages of a hierarchy of dominance? (2 points).

- A) To suppress the aggression.
- B) To diminish the time and the energy invested in fights.
- C) To diminish the mortality of individuals because of the wounds caused in the combat
- D) A and B.
- E) All the above

73. The “coefficient of relatedness” (r) between various kin pairs that changes according to the relationships in any diploid animal ((For example a mammalian like *Canis lupus* (Canidae)) is given in the table below. (3.5 points).

Parent < > Offspring	0.50
Identical twins	1.00
Grandparent < > Grandchild	0.25
First cousins	0.125
Uncle < > nephew	0.25

73.1. In view of this, in a haplodiploid bumblebee species *Bombus terrestris* L, 1758 (Apoidea: Hymenoptera), show the coefficient of relatedness (r) in the situations given below. (2.5 points).

- Mother < > Daughter _____
- Father > Daughter _____
- Mother < > Son _____
- Sisters _____
- Brothers _____

73.2. If you take into consideration the knowledge given in the table above, which of the following statements about the sterilization of the worker bees given as I, II, III and IV is true? (1 point).

I- For the transmission of the genetic knowledge to the next generation, the sterilization of the worker bee, is harmful for it.

II- For the transmission of the genetic knowledge to the next generation, the sterilization of the worker bee, is beneficial for it.

III- For the transmission of the genetic knowledge to the next generation, there is no difference on the individual level.

IV- This is an example of altruism.

___A) Only I

___B) Only IV

___C) II and III

___D) II and IV

___E) III and IV

4.4.2. Part B Answer Key

1. Deleted

2. Deleted

3. Deleted

4.

<u>2</u> , <u>6</u>
<u>2</u> , <u>3</u> , <u>4</u> , <u>5</u>
<u>6</u>
<u>1</u> , <u>3</u> , <u>5</u>
<u>1</u> , <u>3</u> , <u>5</u>
<u>8</u>
<u>7</u>

5.

<u>A</u>
<u>B</u>

6.

<u>A</u>
<u>B</u>
<u>C</u>
<u>E</u>
<u>D</u>

F

7.

A) I: 580, II: 340

B) I

8.

DNA Helicase 2

Primase 1

DNA polymerase I

3' → 5' exonuclease activity 5

DNA Ligase 4

Topoisomerase II 6

—

DNA Polymerase I

5' → 3' exonuclease activity 3

9.

A)

Theoretical Test - Part B

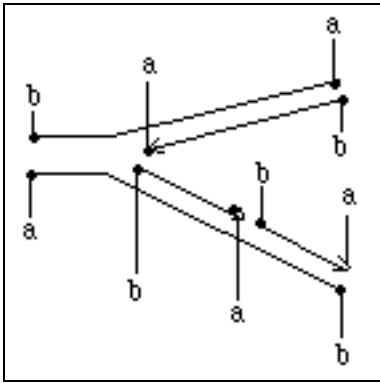

B)

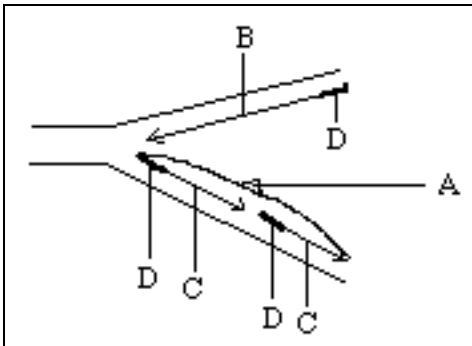

C)



10.



Report of the 11th IBO in Antalya

<u>D</u>	<u>D</u>
<u>C</u>	<u>C</u>
<u>F</u>	<u>E</u>
<u>H</u>	<u>G</u>

11. Deleted

12. Deleted

13.

<u>P</u>
<u>E</u> , <u>P</u>
<u>P</u>
<u>P</u>
<u>E</u> , <u>P</u>
<u>P</u> , <u>E</u>
<u>P</u>

14.

A) 5'GAA GGG CUA UCC UUA UCA AAG
B) Glu-Gly-Leu-Ser-Leu-Ser-Lys-
C) Leu-stop-stop
D) B
E) H

Theoretical Test - Part B

15. Deleted

16. Deleted

17.

- B
- D
- C
- A

18.

- A)
 - X
 - X
 -
 - X
 -
- B)
 - ammonia
 - nitrite
 - nitrate
 - nitrogen gas

19.

- a. 0.49
- b. 0.25

20.

5/8 or 62.5%

21. Deleted

22.

- A) 3
- B) 14.98 or $15.0 > 7.815 - 387.45$ or $387 > 7.815$
- C) Genes are linked
- D) Deleted

23.

- 1
- 4
- 5
- 3
- 2

24.

A, D

25.

A)	+	-
B)	-	+
C)	+	-
D)	-	+
E)	+	-
F)	-	+

Theoretical Test - Part B

26. Deleted

27. Deleted

28. Deleted

29. Deleted

30.

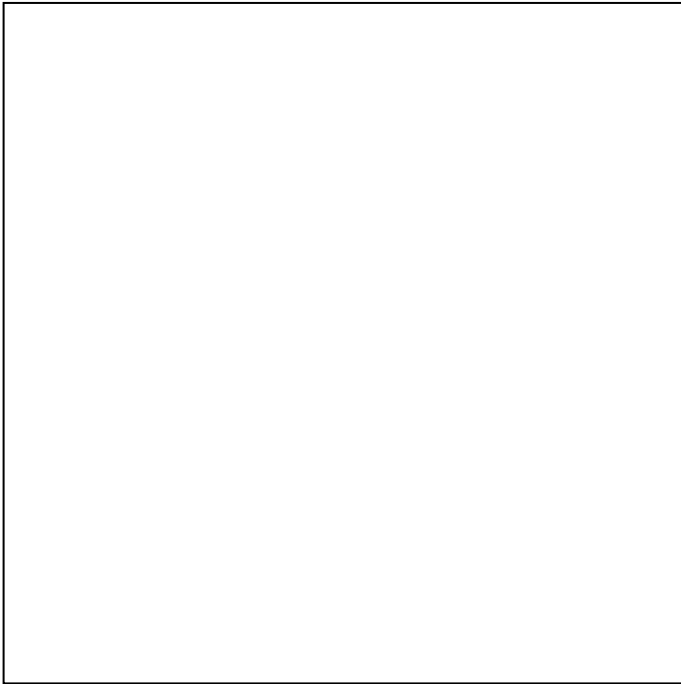

31.

- 31.1. E
- 31.2. B

32.

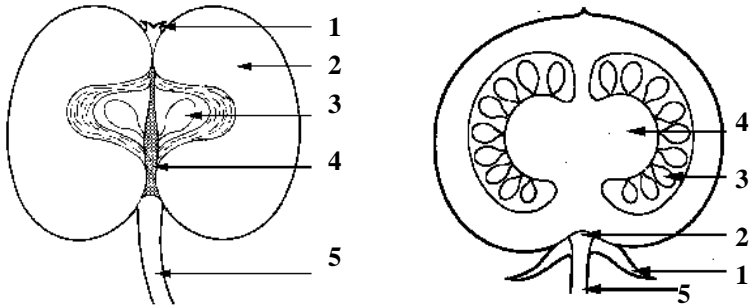

33. Deleted

34. Deleted

35.

35.1.

	Increases	Decreases
Membrane potential		X
pH of the medium	X	

35. 2.

	Taken up	Not taken up
Glucose	X	

36. Deleted

37. Deleted

38.

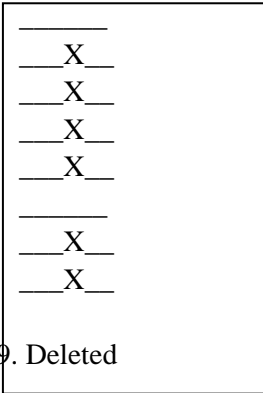

39. Deleted

40. Deleted

41.

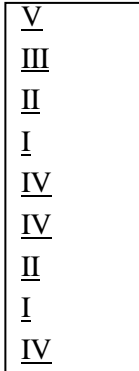

42. Deleted

Report of the 11th IBO in Antalya

43.

	Fresh water fish (carp)	Bird (pigeon)	Marine fish (sea bass)	Lizard (Chameleon)	Marine mammal (whale)	Terrestrial mammal (Mouse)
Drinks water regularly		X	X			X
Does not drink water	X			X	X	X
Wastes are discarded as ammonia	X		X			
Wastes are discarded as urea					X	X
Wastes are discarded as uric acid		X		X		
Actively secretes salt			X			
Actively absorbs salt	X					
Excretes hipotonic urine relative to the body fluids	X					
Excretes isotonic urine relative to the body fluids			X			
Excretes hipertonic urine relative to the body fluids		X		X	X	X

Theoretical Test - Part B

44.

<u>II</u>
<u>I</u>
<u>III</u>
<u>IV</u>
<u>V</u>

45.	Stimulus	Stimulated organ/tissue	Secreted substance	Target	Biological Response
	Decreased red blood cell count	2	4	7	12

46. Deleted

47. IV
I
III
II

48.1. G

48.2. 1:7

49.

Stretch receptors		Cardioacceleratory center		Cardioinhibitory center		Vasomotor center	
Stimulated	inhibited	stimulated	inhibited	stimulated	inhibited	stimulated	inhibited
X			X	X			X

Report of the 11th IBO in Antalya

Cardiac output		Arterioles	
increases	decreases	constricted	dilated
	X		X

50. Deleted

51.

1	3	2	13	11	1	8
I	II	III	IV	V	VI	VII

52.

RQ higher	RQ lower
X	
	X
	X
X	

53.

<u>II</u>
<u>V</u>
<u>IV</u>
<u>III</u>
<u>I</u>

Theoretical Test - Part B

54.

Arterial chemoreceptors		Respiratory rate	
stimulation	inhibition	increase	decrease
X		X	

H ⁺ excretion in the kidneys		Blood partial CO ₂ pressure	
increase	decrease	increase	decrease
X			X

55.

<u>3</u>

<u>1, 2, 3, 4</u>
<u>1, 2, 3, 4</u>
<u>1, 2, 3, 4</u>

56.

<u>A</u>
<u>C</u>
<u>B</u>
<u>E</u>

57.

- 5
- 3
- 2

4

9

1

7

8

6

58. Deleted

59. Deleted

60. Deleted

61. Deleted

62.

- A
- E
- B,D
- C
- F
- F

63.

64.

Competition	
<u>Species</u>	
A	B
-	-
+	-
0	0
+	+
+	0
-	0

Predation	
<u>Species</u>	
A	B
-	-
+	-
0	0
+	+
+	0
-	0

Parasitism	
<u>Species</u>	
A	B
-	-
+	-
0	0
+	+
+	0
-	0

Neutralism	
<u>Species</u>	
A	B
-	-
+	-
0	0
+	+
+	0
-	0

Mutualism	
<u>Species</u>	
A	B
-	-
+	-
0	0
+	+
+	0
-	0

Commensalism	
<u>Species</u>	
A	B
-	-
+	-
0	0
+	+
+	0
-	0

Amensalism	
<u>Species</u>	
A	B
-	-
+	-
0	0
+	+
+	0
-	0

Report of the 11th IBO in Antalya

65. 12

7, 8, 9, 10, 11

1, 2, 3, 4, 5, 6

1, 2, 3, 5

66. Deleted

67. 9

3

4,5,7

1

2,8,10

6

68. III

II

IV

I

69. Deleted

Theoretical Test - Part B

70. X

 X

 X

 X

71. N2

72.1. A

72.2. Deleted

72.3. Deleted

72.4. E

73.1. 0.50

1.00

0.50

0.75

0.50

73.2. D