



All IBO examination questions are published under the following Creative Commons license:



CC BY-NC-SA (Attribution-NonCommercial-ShareAlike) - <https://creativecommons.org/licenses/by-nc-sa/4.0/>

The exam papers can be used freely for educational purposes as long as IBO is credited and new creations are licensed under identical terms. No commercial use is allowed.

Country: \_\_\_\_\_

Student Code: \_\_\_\_\_

## 19<sup>th</sup> INTERNATIONAL BIOLOGY OLYMPIAD

13<sup>th</sup> – 20<sup>th</sup> July, 2008

Mumbai, INDIA



### THEORETICAL TEST – PART A

Write all answers in the **ANSWER SHEET**.

## Dear Participants

- You have a total of 2 hours for answering Part A.
- The questions in Part A have **only one** correct answer. Mark the correct answer with 'X' on the **Answer Sheet**, which is provided separately. The correct way of marking the cross is shown below. Use a pen or a dark pencil to mark your answers.

Q. NO.	a	b	c	d	e
20		X			

- The answers written in the Question Paper will not be evaluated.
- Mark your answers clearly. Avoid any corrections in the Answer Sheet.
- NOTE: Some of the questions may be marked “Skipped” / “Deleted”. DO NOT attempt these questions. Also, read the question completely before attempting it as some questions may continue from one page to the next.
- The maximum number of points is **63**.
- Your Answer Sheets will be collected at the end of the examination.

Good Luck!!

---

Country: \_\_\_\_\_

First name: \_\_\_\_\_

Middle name: \_\_\_\_\_

Family name: \_\_\_\_\_

Student Code: \_\_\_\_\_

**PART A**

**CELL BIOLOGY (13 points)**

1. (1 point) The central dogma originally proposed by Francis Crick has seen changes reflecting new insights obtained from time to time. Which one of the following schematics correctly depicts our current understanding of the replication of genetic material in various organisms and the “flow of information” in biological systems?

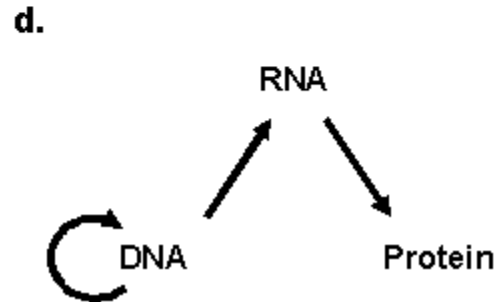
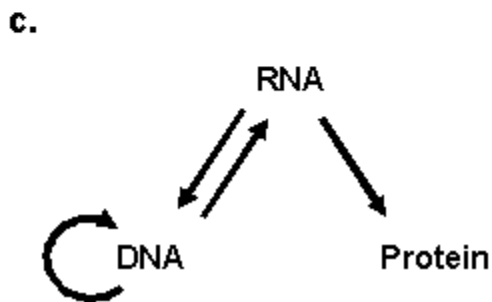
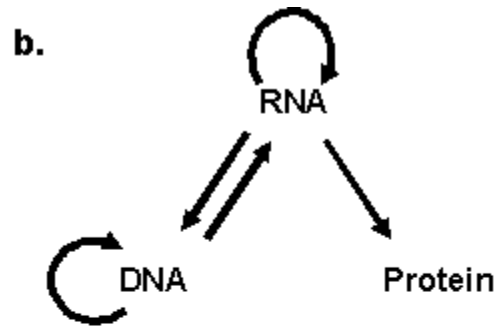
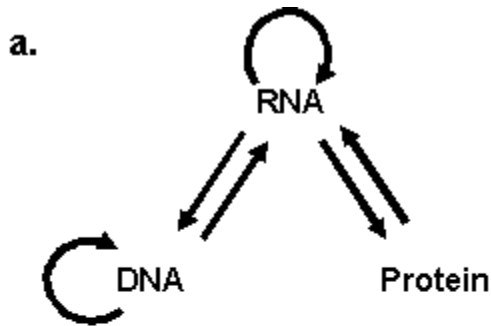

2. (1 point) In an experiment, mice were injected intravenously with uniformly labeled [ $^{14}\text{C}$ ] – glucose. The molecules in the body where the  $^{14}\text{C}$  would be found are:
- essential amino acids and proteins.
  - lipids and all vitamins.
  - proteins and lipids.
  - proteins and all vitamins.

3. (1 point) The following schematics depict the orientation of  $F_1F_0$ -ATPase along with the direction of  $H^+$ -transport and ATP synthesis/hydrolysis.

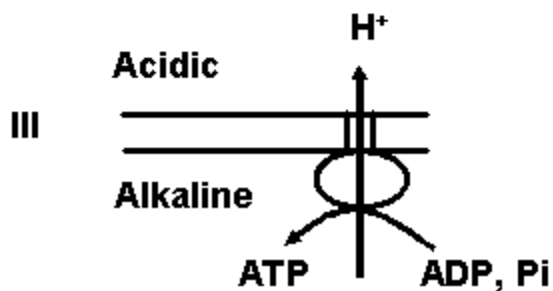
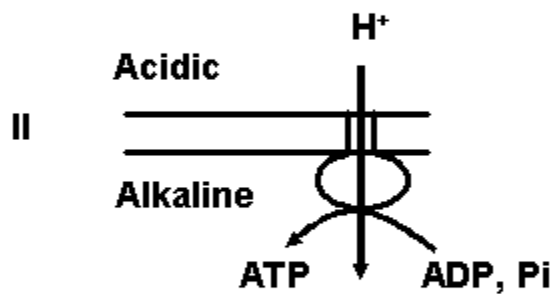
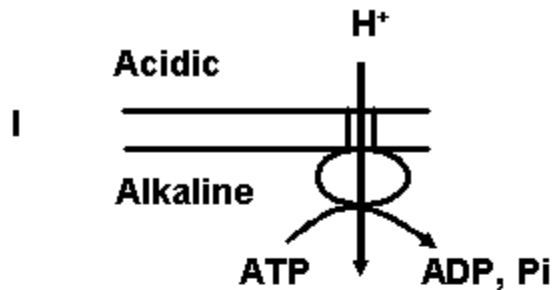

Of the above schematics,

- Only I is correct.
- Only II is correct.
- Only III is correct.
- Both I and III are correct.

4. (1 point) A given DNA sample has 60% purines. The source of this DNA is most likely to be:
- a. a eukaryotic cell.
  - b. a bacterial cell.
  - c. a bacteriophage with double-stranded DNA.
  - d. a bacteriophage with single-stranded DNA.

5. (1 point) The stage of cell division shown in the figure below represents:

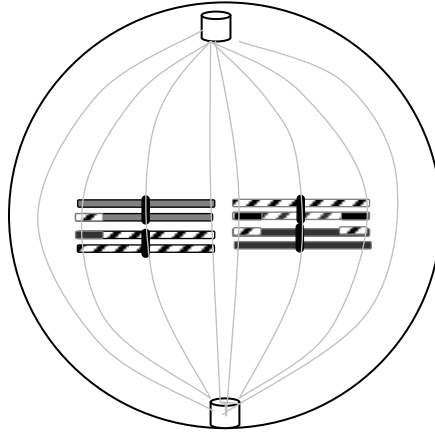

- a. Meiotic metaphase I with  $n = 4$
- b. Meiotic metaphase II with  $n = 4$
- c. Meiotic metaphase II with  $n = 8$
- d. Meiotic metaphase I with  $n = 2$



6. (1 point) Polymerase Chain Reaction (PCR) is a technique for rapid amplification of DNA segments. If you are given double-stranded DNA with appropriate forward and reverse primers as shown in the figure below, the minimum number of cycles you will require to obtain at least one copy of the desired fragment PQ will be:

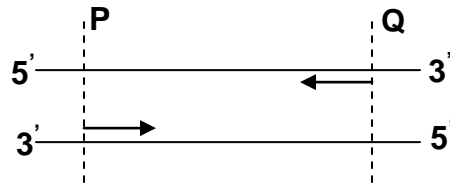

- a. 1
- b. 3
- c. 4
- d. 40

7. (1 point) Which of the primer pairs is the correct one to amplify the gene sequence below with PCR?

5'-GCGTTGACGGTATCAAAACGTTAT... ..TTTACCTGGTGGGCTGTTCTAATC-3'

- a. 5'-GCGTTGACGGTATCA-3' and 5'-TGGGCTGTTCTAATC-3'
- b. 5'-CGCAACTGCCATAGT-3' and 5'-TGGGCTGTTCTAATC-3'
- c. 5'-GCGTTGACGGTATCA-3' and 5'-GATTAGAACAGCCCA-3'
- d. 5'-TGATACCGTCAACGC-3' and 5'-GATTAGAACAGCCCA-3'

8. (1 point) Equal concentrations of urea, ethyl urea, and dimethyl urea were separately added to a suspension of red blood cells (RBC). The relative rates of diffusion of these molecules into RBCs will be:

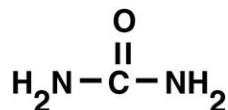

1. Urea

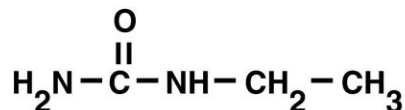

2. Ethyl urea

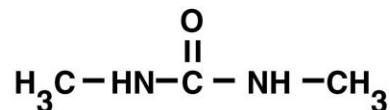

3. Dimethyl urea

- a.  $1 > 2 > 3$   
b.  $1 > 2 = 3$   
c.  $3 > 2 > 1$   
d.  $3 = 2 > 1$

9. (1 point) A region of a double-stranded DNA is represented in the following schematic and the hyphens denote sequences of unspecified lengths:

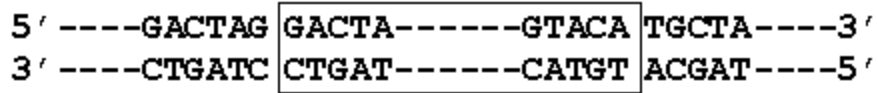

The region of DNA enclosed within the box undergoes inversion. Which one of the following correctly depicts the above DNA after inversion?

- a. 

```
5' ----GACTAG ACATG-----ATCAG TGCTA----3'
3' ----CTGATC TGTAC-----TAGTC ACGAT----5'
```
- b. 

```
5' ----GACTAG ATCAG-----ACATG TGCTA----3'
3' ----CTGATC TAGTC-----TGTAC ACGAT----5'
```
- c. 

```
5' ----GACTAG TGTAC-----TAGTC TGCTA----3'
3' ----CTGATC ACATG-----ATCAG ACGAT----5'
```
- d. 

```
5' ----GACTAG CTGAT-----CATGT TGCTA----3'
3' ----CTGATC GACTA-----GTACA ACGAT----5'
```

10. (1 point) A rare genetic disease is characterized by immuno-deficiency, developmental and growth delay, and microcephaly. Suppose you extract DNA from a patient with this syndrome and find almost equal quantities of long and very short DNA strands, which enzyme is likely to be defective in this patient?

- a. DNA ligase
- b. Topoisomerase
- c. DNA polymerase
- d. Helicase

11. (1 point) A scientist has suggested that a homolactic fermenting organism grows anaerobically on glycerol 3-phosphate as the sole source of carbon, exclusively using the following pathway:

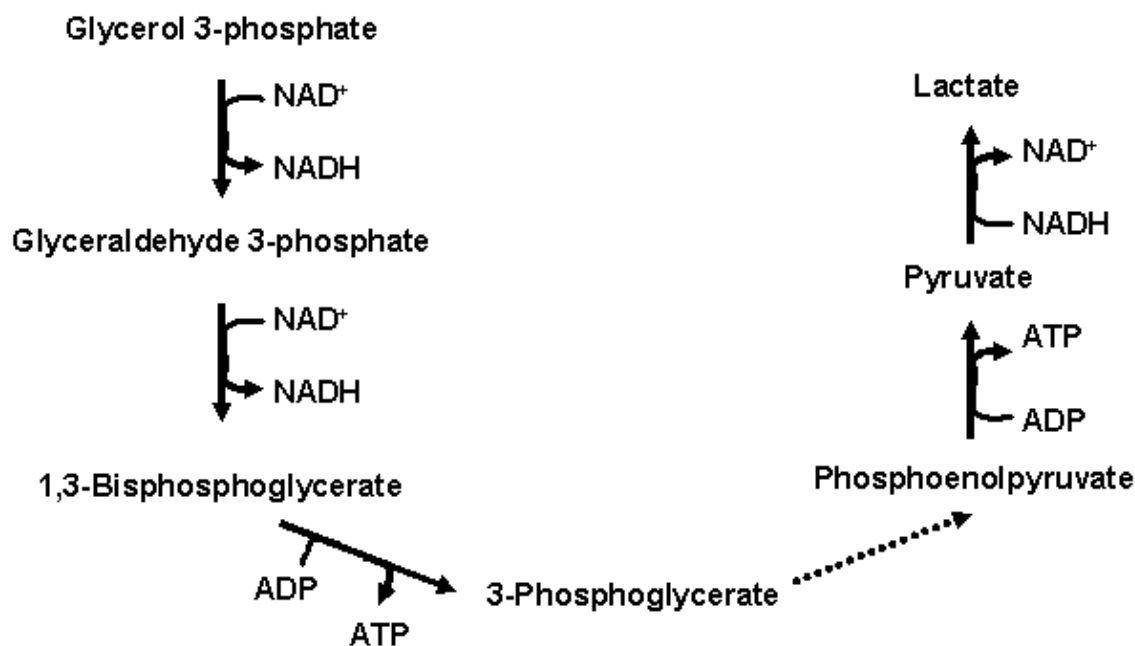

However, the scientific community rejected this suggestion because:

- the number of ATP molecules produced is insufficient to support growth.
- the number of  $\text{NAD}^+$  that are reduced is not same as the number of  $\text{NADH}$  that are oxidized in the pathway.
- the carbon source is not as reduced as glucose and hence, cannot support growth.
- the number of negative charges on lactic acid (which is being produced) is not the same as that on glycerol 3-phosphate (which is being consumed).

12. (1 point) The growth curve of a bacterial culture grown in a rich medium at 37°C is shown in Figure A. The same organism when exposed to 45°C for 30 min and then inoculated into a rich medium at 37°C, exhibited a growth curve shown in Figure B.

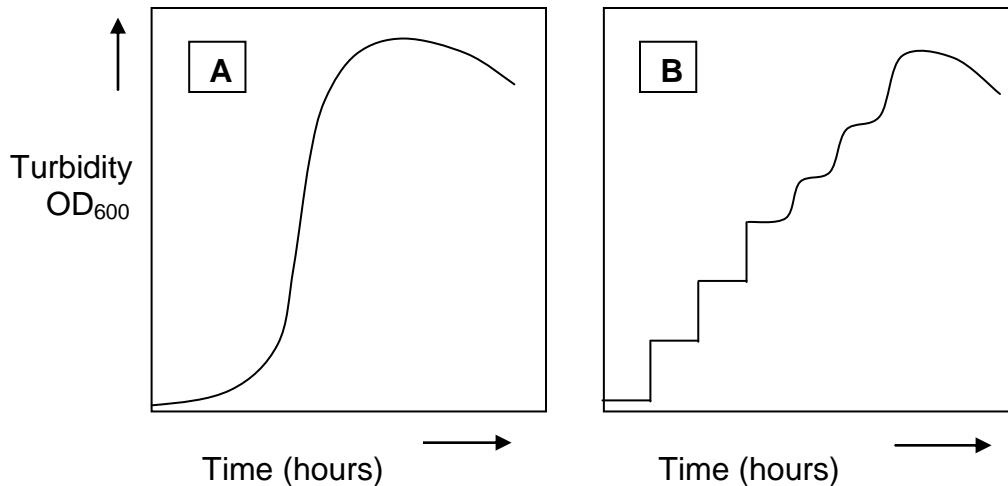

Which of the following statements is most likely to explain the growth pattern in Figure B?

- Heat kills the original bacterial population and the growth pattern observed is due to a contaminating bacterial strain.
- Heat causes growth arrest at a particular stage, thereby synchronizing cells and resulting in all cells dividing at the same time.
- Heat exposure alters surface properties of cells causing errors in turbidity measurements.
- The increase in turbidity is not due to growth but caused by increasing lysis of heat-treated cells with time.

13. (1 point) Absorption of a drug in the gastro-intestinal tract depends on a number of factors. Penicillin V, whose structure is shown below, is a weak acid ( $pK_a = 2.7$ ). The pH in stomach is about 2.0 and that in the intestine is 7.5. Most of the drug is absorbed in the intestine.

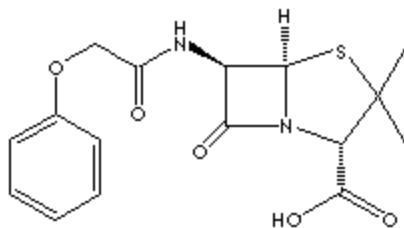

Choose the most likely reason for this from the following statements:

- The molecule of drug being hydrophobic in nature passes through gastric and intestinal membranes to a very small extent. However, because of the much greater surface area in the intestine, the major quantity of the drug is absorbed here.
- The un-ionized form of the drug prevails in stomach, which slows down its absorption. Hence, the drug gets preferentially absorbed in the intestine.
- The ionized form of the drug prevails in the intestine which hinders/slows down its absorption. However, owing to the large surface area available in the intestine, the drug is absorbed mainly here.
- Due to rapid churning movement and the low pH in the stomach, the drug is completely broken down into smaller fragments, which are subsequently absorbed in the intestine.



**PLANT SCIENCES (9 points)**

14. (1 point) Which of the following will harm a dicotyledonous plant the most?
- a. Removal of the central pith
  - b. Removal of the cork
  - c. Removal of the bark
  - d. Removal of the cork cambium

15. (1 point) The transverse sections of the leaves A and B given below represent, respectively:

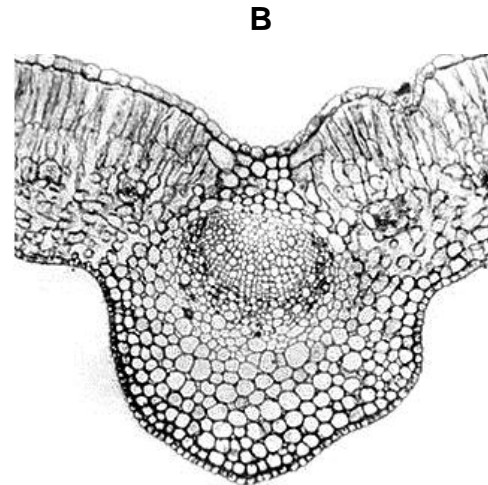
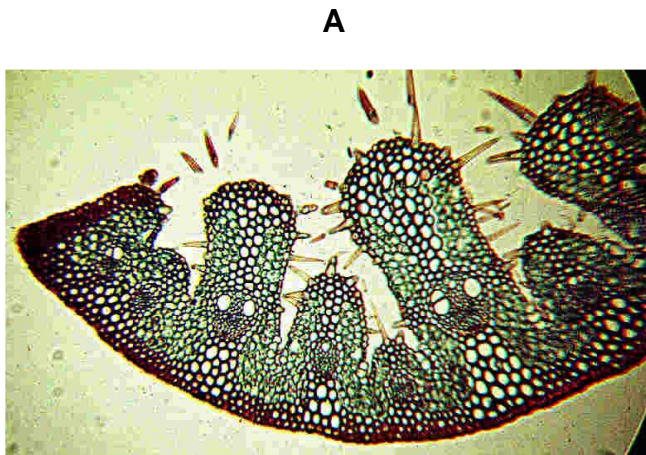

- a. a xerophyte and a mesophyte.
- b. a xerophyte and a floating hydrophyte.
- c. a floating hydrophyte and a submerged hydrophyte.
- d. a submerged hydrophyte and a xerophyte.

16. (1 point) Certain plant species such as Red Oak (*Quercus rubra*) can tolerate severe drought over a long period of time without affecting its photosynthesis.

Which of the following adaptations is likely to contribute to this ability?

- a. Stomatal closure
- b. Large negative leaf water potential
- c. Kranz leaf anatomy
- d. Fibrous root system that increases root surface area

17. (1 point) The net assimilation of  $\text{CO}_2$  of a plant is 0.5 moles when illuminated during the day. The net consumption of  $\text{O}_2$  is 0.12 moles during the night.

Assuming that all the gas exchange is due to photosynthesis and respiration of the biomass (equivalent molecular mass of 30), what is the net production or consumption of biomass in grams during a complete 12 h day:12 h night diurnal cycle?

- a. 3.6 g/day
- b. 7.8 g/day
- c. 11.4 g/day
- d. 15.0 g/day

18. (1 point) Choose the figure that correctly represents the photosynthetic efficiencies of  $C_3$  and  $C_4$  plants.

a.

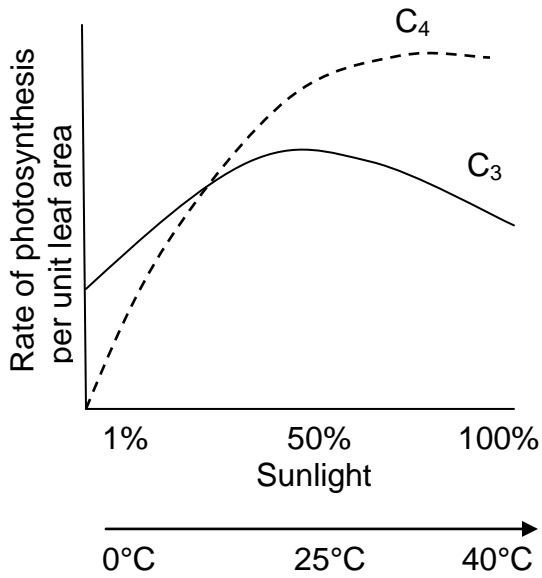

b.

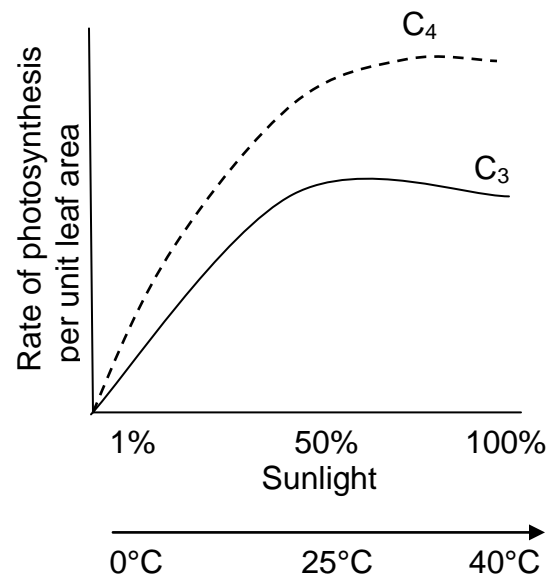

c.

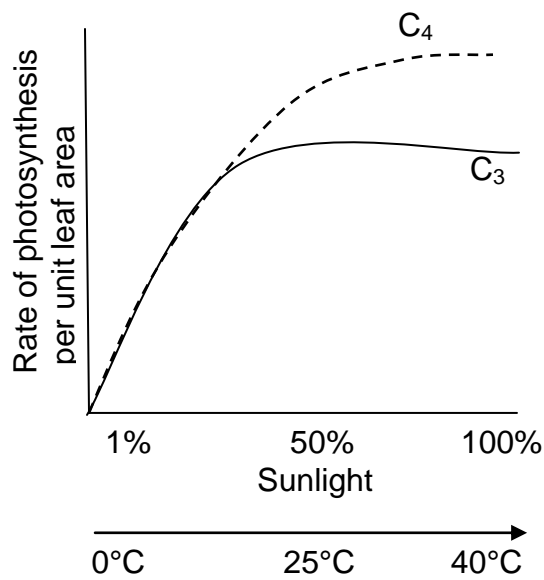

d.

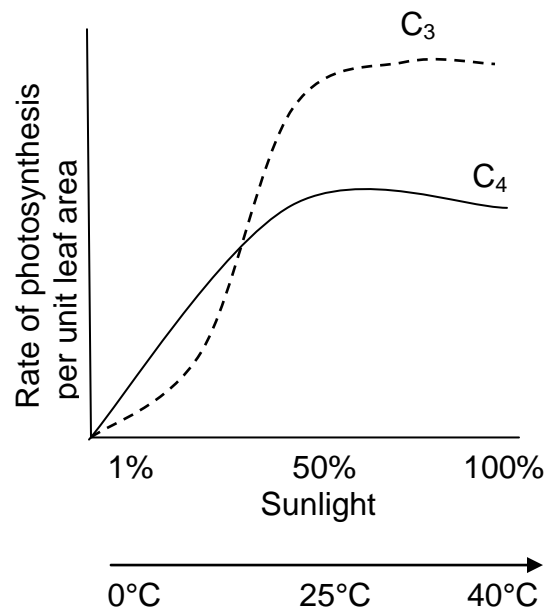

19. (1 point) Plant chloroplasts are believed to have evolved from cyanobacteria-like progenitors through endosymbiosis. Which of the following statements support this hypothesis?

- I. Chloroplasts and cyanobacteria share similar photosynthetic pigments and thylakoid membranes.
- II. Cyanobacteria exhibit an oxygenic photosynthesis.
- III. Chloroplasts are maternally inherited.
- IV. Chloroplasts have their own DNA and ribosomes.
- V. Viable chloroplasts can be isolated from cells but cannot be cultured in vitro.
- VI. Prokaryotic genes express well in chloroplasts.

- a. I, III, IV and V
- b. I, II, IV and VI
- c. I, II, III and V
- d. II, IV, V and VI

20. (1 point) Powdery mildew is a plant disease caused by an ectoparasitic fungus. The fungal infection can spread to neighboring host cells in the following ways:

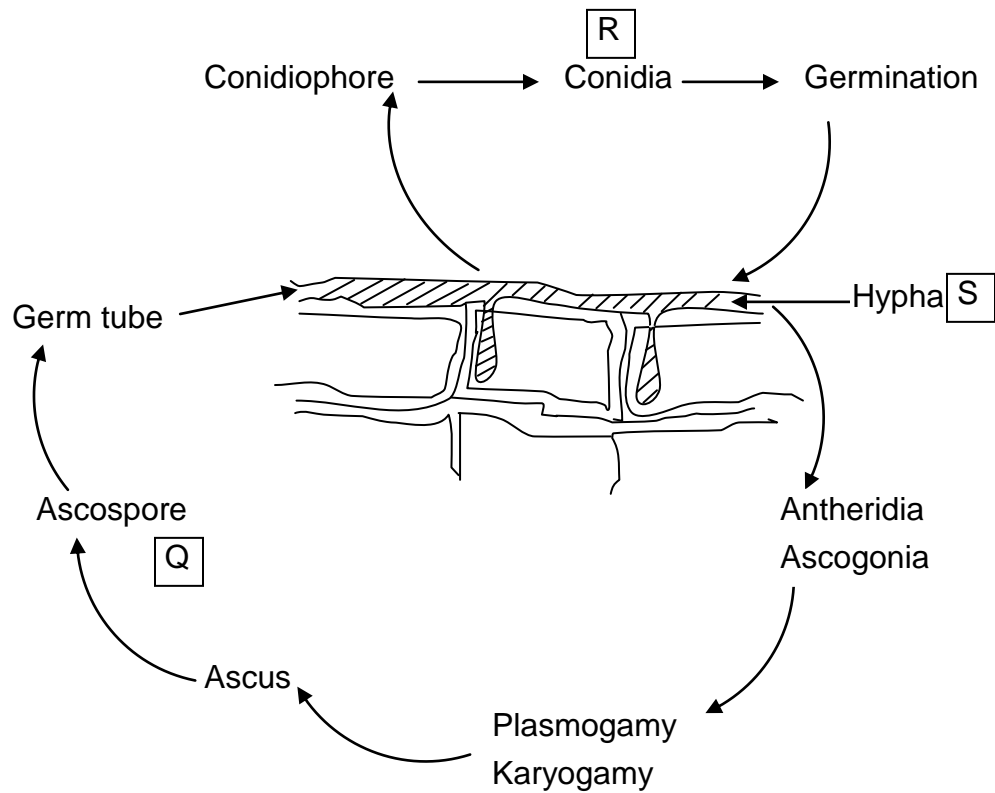

The ploidy levels of the structures Q, R and S are, respectively:

- $2n, n, n$
- $n, n, n$
- $2n, n, 2n$
- $n, n, 2n$





22. (1 point) The stem of a lily plant was placed in water tinted with red ink to monitor the movement of water through it. Two transverse sections of stems are given below. In which of the labeled structures would you expect the red color?

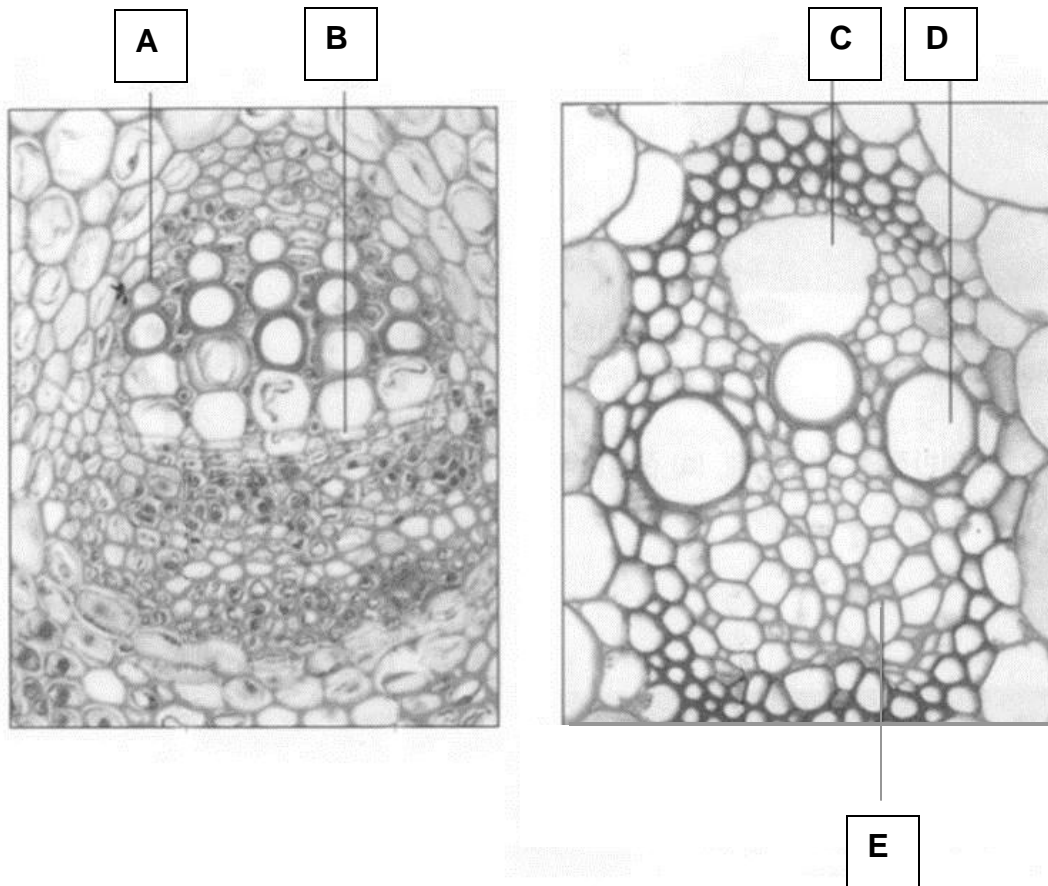

- a. A
- b. B
- c. C
- d. D
- e. E

**ANIMAL SCIENCES (11 points)**

23. (1 point) A few intact skeletons of birds were found during a field trip to the Pampas in Argentina. In all the skeletons examined, the sternum lacked a keel bone. These skeletons most likely belonged to:
- terrestrial birds capable of short and powerful flight.
  - flightless aquatic birds.
  - insectivorous flying birds.
  - flightless terrestrial birds.

24. (1 point) Which one of the following is a feature of a heterothermic

endotherm?

- a. Its body temperature can vary, but it produces heat from its own tissues.
- b. Its body temperature varies because it gains most of the heat from sources outside its body.
- c. Its body temperature does not vary because it produces heat from its own tissues.
- d. Its body temperature does not vary even though it gains heat from sources outside its body.

25. (1 point) Which of the following will be an advantage of breathing in air over breathing in water?

- I. As air is less dense than water, less energy is required to move air over respiratory surfaces.
  - II. Oxygen diffuses faster through air than it does through water.
  - III. The oxygen content of air is greater than that of an equal volume of water.
- 
- a. Only I and II
  - b. Only I and III
  - c. Only II and III
  - d. I, II and III

26. (1 point) Which characteristics would allow you to declare an organism found on a beach as an echinoderm?
- a. Radially symmetric adults with presence of spines and tube feet.
  - b. Radially symmetric adults with dorsal hollow notochord.
  - c. Exoskeleton with pharyngeal gill-slits and tube feet.
  - d. Radially symmetric adults with mantle cavity.

27. (1 point) In an individual X, the pituitary gland was found to function normally while the adrenal glands were atrophied. In another individual Y, both the pituitary and adrenal glands were found to be underdeveloped. If adrenocorticotrophic hormone (ACTH) is administered to these individuals as a remedial measure, it will be effective in:

- a. individual X alone.
- b. individual Y alone.
- c. both X and Y.
- d. neither X nor Y.

28. (1 point) Which of the following are associated with stereoscopic vision?

- I. Effect of the blind spot of one eye is cancelled by the other eye.
- II. Total visual field of  $360^\circ$  and frontal visual field of  $30^\circ$ .
- III. More likely to be observed in predatory birds.
- IV. Centrally situated fovea that gives good visual acuity.

- a. I, II and IV
- b. I, II and III
- c. II, III and IV
- d. I, III and IV

29. (1 point) The glycoside “Phloridzin” present in apple peel can block the normal reabsorption of glucose from kidney tubules. As a result, sugar is almost completely excreted through the urine. A mouse fed with Phloridzin along with sodium succinate will develop:

- a. hypoglycemia and no sugar will be detected in the urine sample.
- b. hyperglycemia and urine test for sugar will be positive.
- c. hyperglycemia and no sugar will be detected in the urine sample.
- d. hypoglycemia and urine test for sugar will be positive.



30. (1 point) Cardiac output is defined as the amount of blood pumped by each ventricle. It is determined by multiplying the heart rate and the stroke volume. The stroke volume is the amount of blood ejected by each ventricle with each beat. If the heart of a woman beats 56 times in a minute, the volume of blood in her heart is 120 ml at the end of diastole and 76 ml at the end of systole, what would be her cardiac output?
- a. 10.976 L/min
  - b. 2.464 L/min
  - c. 6.720 L/min
  - d. 4.256 L/min

31. (1 point) A population is drinking water contaminated with a modified bisphenol-A, which is not degraded in the body. As a result, there are measurable levels of this compound in the blood. Which of the following would result if the modified bisphenol-A were an oestrogen-mimicking compound?

- a. Males would have decreased sperm production.
- b. Males would have elevated levels of follicle-stimulating hormone.
- c. Females would have elevated levels of gonadotropin-releasing hormone.
- d. Males would have elevated levels of blood testosterone.
- e. Follicle stimulation would increase in females.

32. (1 point) If a molecule of carbon dioxide released into the blood in your left foot travels out of your nose, it must pass through all of the following structures except the:

- a. right atrium
- b. pulmonary vein
- c. alveolus
- d. bronchus
- e. pulmonary artery

33. (1 point) The process of artificial kidney dialysis is shown schematically using the following symbols:

- : erythrocyte      ○ : salts       : semi-permeable membrane  
● : urea      ▲ : proteins

Which of the following correctly depicts the process?

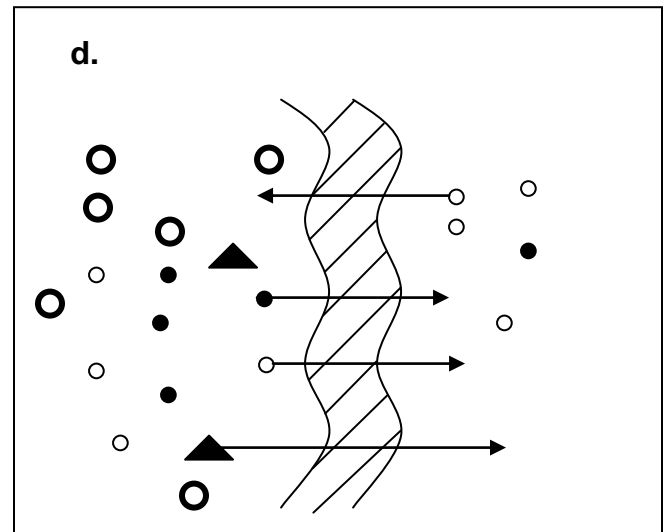
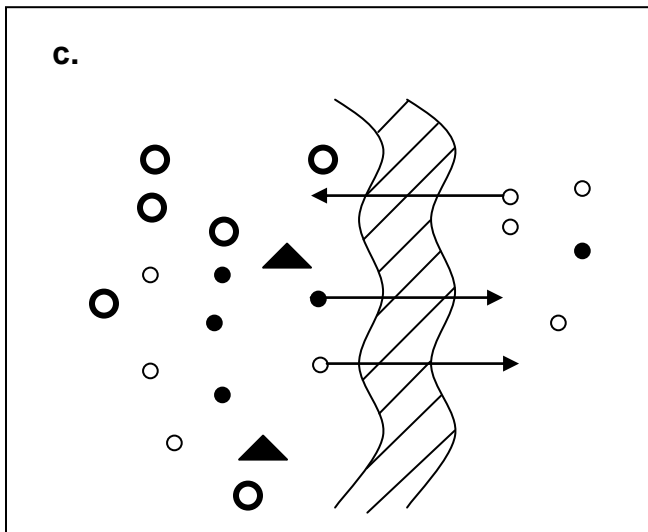
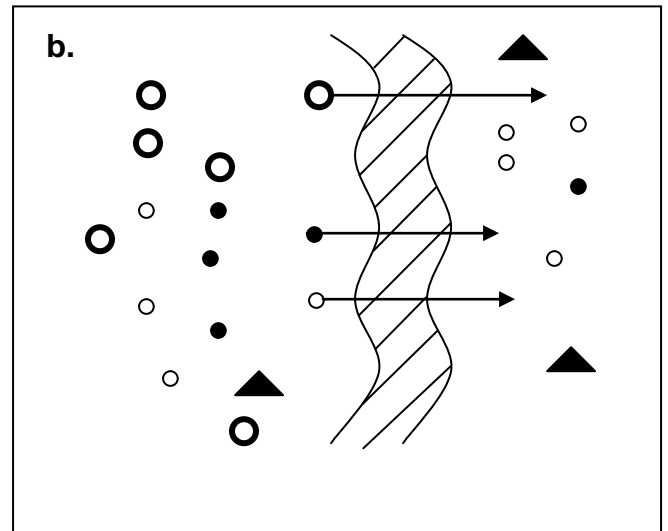
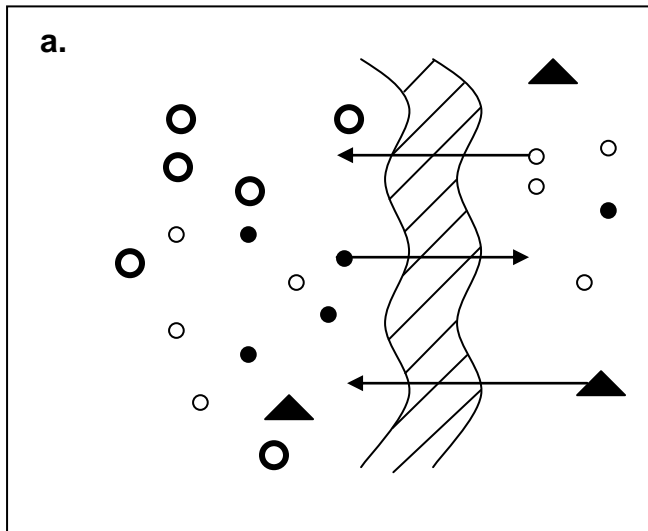

**GENETICS AND EVOLUTION (17 points)**

34. (1 point) A mutation results in the absence of sweat glands, a disease called anhidrotic ectodermal dysplasia. A woman suffering from this disease has a mosaic of skin patches lacking sweat glands. The woman is likely to be:
- homozygous for an autosomal recessive mutation.
  - heterozygous for an autosomal dominant mutation.
  - homozygous for a X-linked recessive mutation.
  - heterozygous for a X-linked recessive mutation.

35. (1 point) A mink breeder allows random mating among his minks. He discovers that, on an average, 9% of his minks have rough fur that fetches less money when sold. So he decides to focus upon smooth fur and does not allow minks with rough fur to mate. Rough fur is linked to an autosomal recessive allele. What is the percentage of minks with rough fur that he will obtain in the next generation?

- a. 7.3
- b. 5.3
- c. 25
- d. 23

36. (1 point) In a breed of rabbits, multiple alleles with the following dominance relationships control coat coloration:

$C$  (agouti)  $>$   $c^{ch}$  (chinchilla)  $>$   $c^h$  (Himalayan)  $>$   $c$  (albino).

An experimental cross between agouti and Himalayan produced 50% agouti and 50% Himalayan progeny. Which of the following crosses could produce this result?

- I.  $Cc^h \times c^hc^h$
  - II.  $Cc \times c^hc$
  - III.  $Cc^h \times c^hc$
  - IV.  $Cc \times c^hc^h$
- 
- a. I, II and III
  - b. II, III and IV
  - c. I, III and IV
  - d. I, II and IV

37. (1 point) Alleles  $I^A$  and  $I^B$  present on chromosome 9 are responsible for blood groups A and B, respectively. Blood group O results when these alleles are either absent or not expressed. The alleles  $I^A$  and  $I^B$  are expressed only if the H allele is present on chromosome 19, either in the homozygous or heterozygous condition, where h stands for the recessive allele.

Gilbert belongs to the AB blood group. His sister Helen belongs to the A group while their father belongs to the O group. Identify the maternal and paternal genotypes.

<u>Mother</u>	<u>Father</u>
a. $H/H, I^A/I^B$	$H/h, I^O/I^O$
b. $H/h, I^B/I^O$	$h/h, I^A/I^O$
c. $h/h, I^O/I^O$	$h/h, I^A/I^O$
d. $H/H, I^A/I^O$	$H/h, I^B/I^O$
e. $h/h, I^B/I^O$	$H/h, I^O/I^O$



38. (1 point) The phenotypes of three experimental populations of plants are shown in the following graphs.

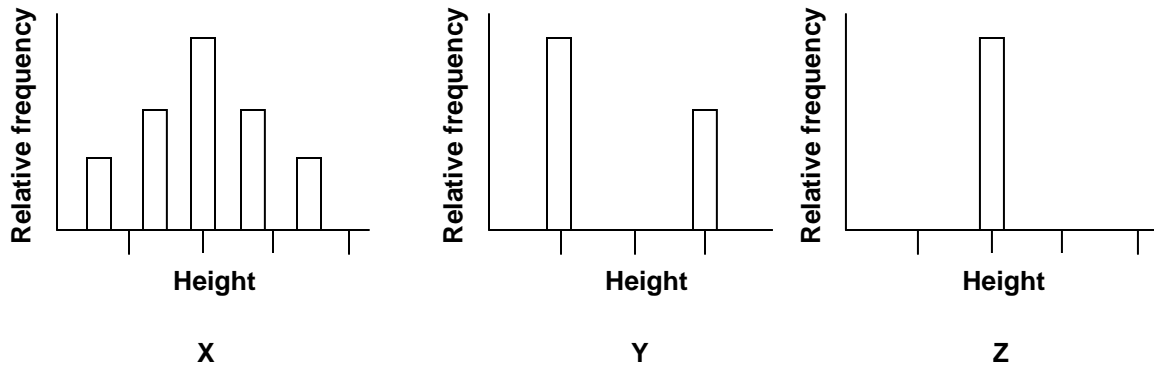

The three populations X, Y and Z represent, respectively:

- a.  $F_1$ ,  $F_2$  and  $F_3$  generations
- b. P,  $F_1$  and  $F_2$  generations
- c.  $F_2$ , P and  $F_1$  generations
- d.  $F_3$ ,  $F_1$  and  $F_2$  generations

39. (1 point) In a population of mice, 40% of males showed a dominant X-linked trait. Assuming random mating, the most frequent mating is expected between the genotypes:

- a.  $X^B X^b$  and  $X^b Y$
- b.  $X^B X^B$  and  $X^b Y$
- c.  $X^B X^b$  and  $X^B Y$
- d.  $X^b X^b$  and  $X^b Y$

40. (1 point) Hunting of Northern elephant seals reduced their population size to as few as 20 individuals at the end of the 19th century. Their population has since rebounded to over 30,000. But their genomes still carry the marks of this bottleneck when compared to the population of Southern elephant seals that was not so intensely hunted. Such bottlenecks are manifested in the form of:

- I. abundance of unique mutations.
  - II. increased frequency of deleterious recessive alleles.
  - III. reduced genetic variation.
  - IV. increased population size.
- 
- a. Only I and II
  - b. Only III
  - c. I, II and IV
  - d. II and III

41. (1 point) What is true for both genetic drift and natural selection?

- I. They are mechanisms of evolution.
  - II. They are entirely random processes.
  - III. They result in adaptations.
  - IV. They affect the genetic make-up of the population.
- 
- a. I and II
  - b. I and III
  - c. II and III
  - d. I and IV

42. (1 point) The frequencies of two codominant alleles with similar fitness values in a laboratory population of mice were 0.55 and 0.45. After 5 generations, the values changed to 0.35 and 0.65, respectively. Which of the following phenomena may be responsible for this observation?

- I. Point mutation
  - II. Nonrandom mating
  - III. Genetic drift
  - IV. Selection pressure
- 
- a. I and IV
  - b. II and IV
  - c. I and III
  - d. II and III

43. (1 point) In pea plants, the allele for green color of seeds ( $G$ ) is dominant over that for yellow color ( $g$ ) while the allele for round seeds ( $R$ ) is dominant over that for wrinkled seed ( $r$ ). The results of an experimental cross with such garden pea plants are tabulated below:

Seed phenotype	Number
Green and round	32
Green and wrinkled	28
Yellow and round	12
Yellow and wrinkled	9

The parental genotypes are likely to be:

- a.  $GgRr$  and  $Ggrr$
- b.  $Ggrr$  and  $GgRR$
- c.  $GgRr$  and  $GgRr$
- d.  $GgRR$  and  $ggRr$

44. (1 point) A population has 6 times as many heterozygous as homozygous recessive individuals. The frequency of the recessive allele will be:

- a.  $1/3$
- b.  $1/4$
- c.  $1/2$
- d.  $1/6$

45. (1 point) If you have data on genotypic frequencies for several generations of a population and if you apply the Hardy-Weinberg equation to it, which of the following can be deduced?

- I. Whether evolution has occurred in the population.
  - II. The direction of evolution, if it has occurred.
  - III. The cause of evolution, if it has occurred.
- 
- a. Only I and II
  - b. Only I and III
  - c. Only II and III
  - d. I, II and III



46. (1 point) The residues of mines often contain such high concentrations of toxic metals (e.g., copper, lead) that most plants are unable to grow on them. However, in a particular study, certain grasses were found to spread from the surrounding uncontaminated soil onto such waste heaps. These plants developed resistance to the toxic metals while their ability to grow on uncontaminated soil decreased. As grasses are wind-pollinated, breeding between the resistant and non-resistant populations went on. But eventually, the less resistant plants growing on contaminated soil and the more resistant plants growing on uncontaminated soil died out. This process is indicative of:

- a. mass extinction of species.
- b. bottleneck effect.
- c. **divergent** evolution.
- d. disruptive selection.

47. (1 point) Sickle cell anemia is an autosomal recessive trait. Individual 2 in the following pedigree is a carrier for this trait. Assuming that individuals 3 and 4 are normal homozygous, what is the probability that individual 6 will have the disease?

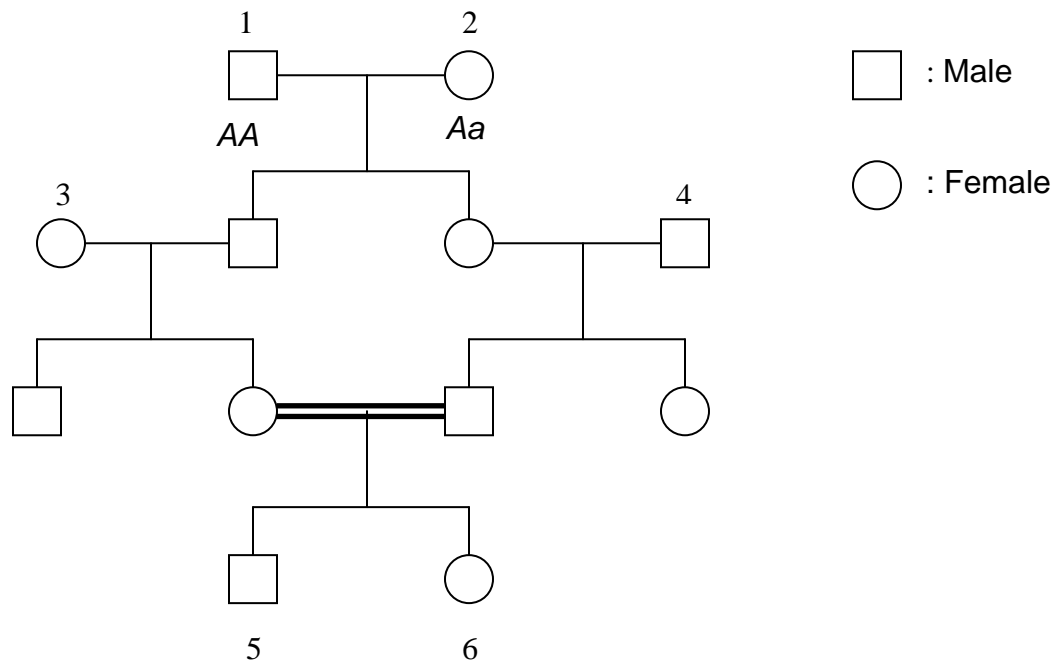

- a. 1/16
- b. 1/32
- c. 1/64
- d. 1/128

48. (1 point) Note the following genotypes and corresponding phenotypes:

A–B– Agouti

A–bb Albino

aaB – Black

aabb Albino

The biochemical process that can explain the above pattern is:

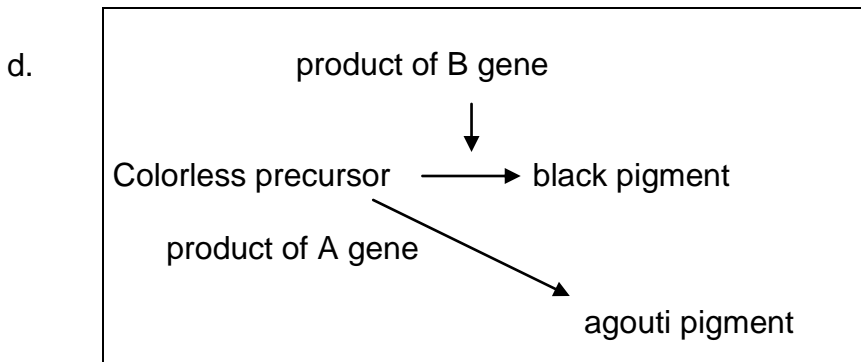
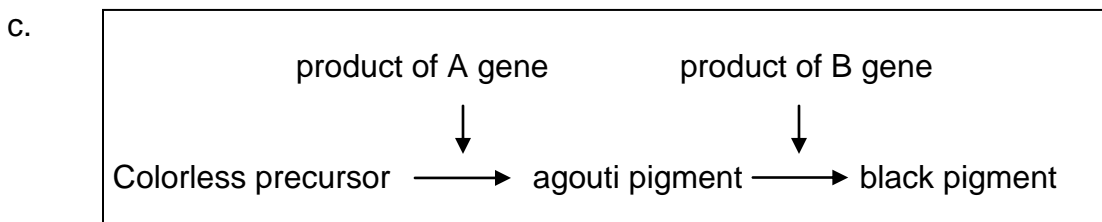
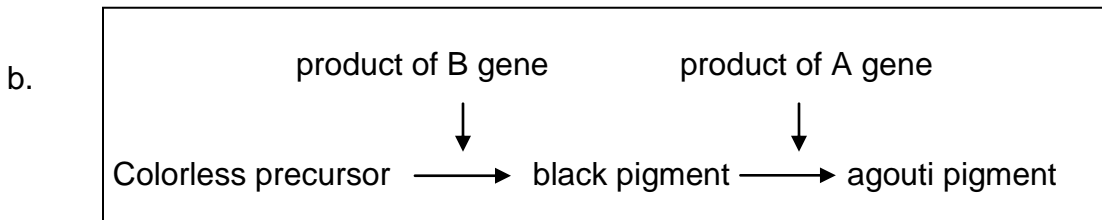
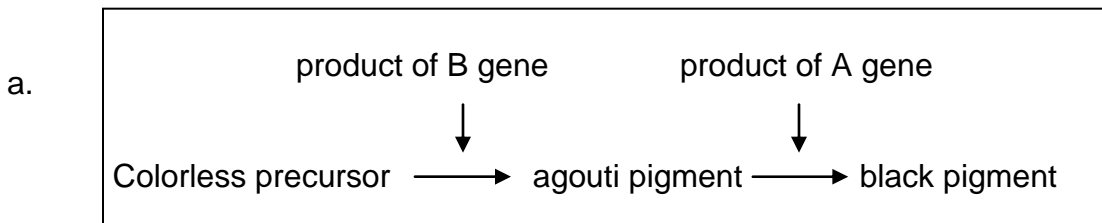

49. (1 point) In a population, 90% of the alleles at the Rh locus are 'R'. Another alternative form of this allele is 'r'. Forty children from this population go to a particular play school. The probability that all are Rh positive is:

- a.  $40^{0.81}$
- b.  $0.99^{40}$
- c.  $40^{0.75}$
- d.  $1-0.81^{40}$

50. (1 point) Study the pedigree and answer the following question.

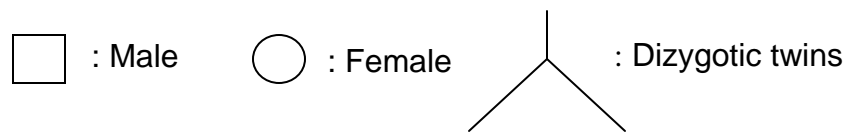
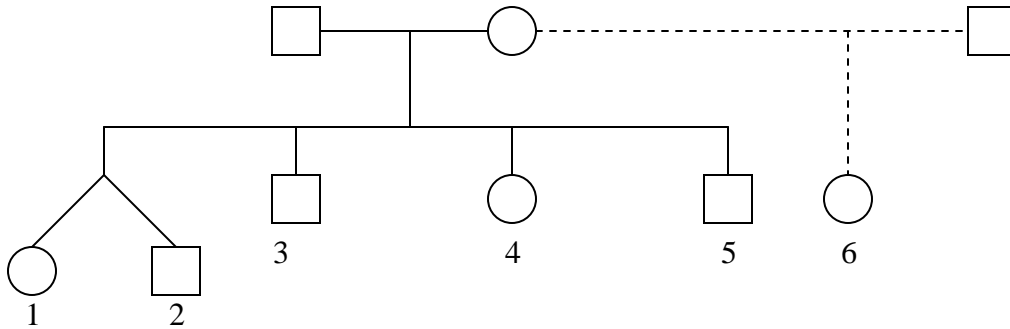

The genetic relatedness between individuals 1 and 2 and between individuals 5 and 6, respectively, is:

- a. 0.5 and 0.25
- b. 0.25 and 0.5
- c. 1.0 and 0.5
- d. 1.0 and 0.25

**ECOLOGY (7 points)**

51. (1 point) A typical biomass pyramid is represented in the figure below.

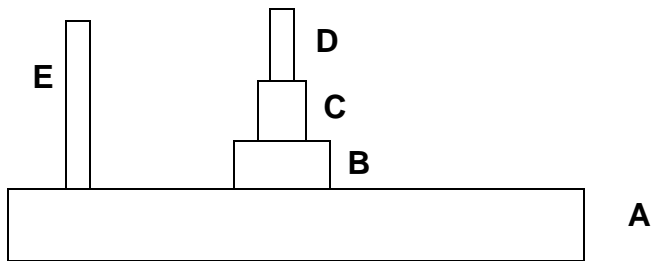

If A represents a primary producer, then E is likely to be a:

- a. photo-litho-heterotroph.
- b. chemo-organo-heterotroph.
- c. chemo-litho-autotroph.
- d. photo-organo-heterotroph.

52. (1 point) Comparative sensitivity of three groups of organisms to single large doses of x-or  $\gamma$ -rays delivered at short intervals is shown in the figure below.

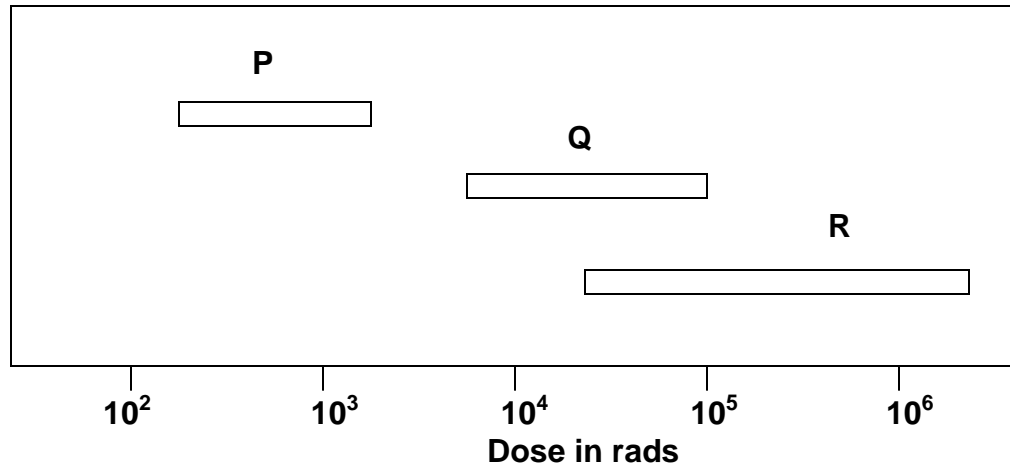

The three groups P, Q, R respectively are:

- insects, mammals and bacteria
- mammals, bacteria and insects
- bacteria, mammals and insects
- mammals, insects and bacteria

53. (1 point) Hay is boiled in water and cooled. Some pond water, containing only heterotrophic protozoa, is added to it and kept in the dark for a long time.

Which of the following are true?

- I. Heterotrophic succession of protozoa will occur with increase in total biomass.
  - II. The energy of the system is maximum at the beginning.
  - III. Succession will occur, eventually reaching a steady state in which energy flow is maintained.
  - IV. The ecosystem may undergo succession but finally all organisms will die or go into resting stages.
- 
- a. I and III
  - b. II and IV
  - c. II and III
  - d. I and IV



54. (1 point) An ecologist is comparing the growth of a herbaceous plant species growing in two different sites A and B. To compare the populations from the two sites, she has harvested 30 individuals from each site, then measured the root length, root biomass, and shoot biomass of each individual. A summary of those measurements are as follows:

Location	Mean root length (cm)	Mean root biomass (g)	Mean shoot biomass (g)
Site A	$27.2 \pm 0.2$	$348.7 \pm 0.5$	$680.7 \pm 0.1$
Site B	$13.4 \pm 0.3$	$322.4 \pm 0.6$	$708.9 \pm 0.2$

Based on the data presented, which of the following statements is likely to be true?

- a. Soil water availability is lower in Site B than in Site A.
- b. Plant productivity is higher in Site A than in Site B.
- c. Soil water availability is lower in Site A than in Site B.
- d. Soil nutrient availability is lower in Site B than in Site A.

55. (1 point) In an aquatic ecosystem, the total dry biomass of each of three groups of organisms is as follows:

- I. Ciliates: 1.1041 g
- II. Midge larvae: 0.9845 g
- III. Oligochaetes: 1.005 g

The correct food chain that they represent is:

- a. I → II → III
- b. II → I → III
- c. I → III → II
- d. III → II → I
- e. II → III → I

56. (1 point) The reproductive effort of a plant is defined as the ratio of the dry weight of its reproductive organs to that of its above-ground tissues. The reproductive effort of two plant species M and N, as compared to their leaf biomass is plotted in the graph below.

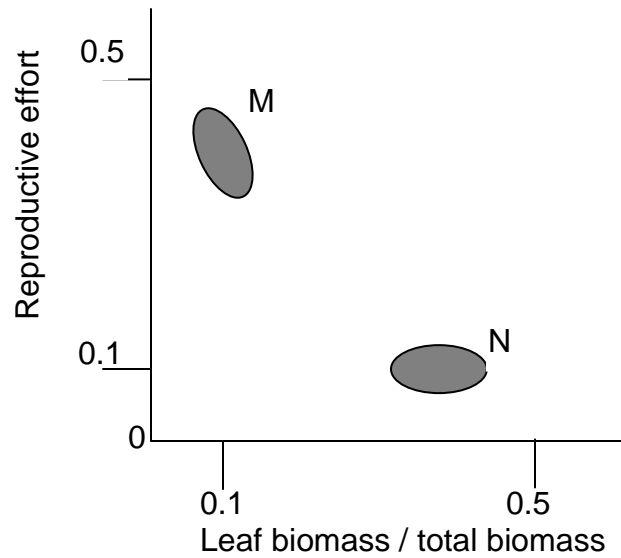

Choose the correct interpretation.

- a. M is a r-strategist adapted to a highly disturbed habitat.
- b. N is a k-strategist adapted to a highly disturbed habitat.
- c. N is a r-strategist growing under favorable environmental conditions.
- d. M is a k-strategist growing under favorable environmental conditions.

57. (1 point) Prey-predator relationships are often considered analogous to a 'life-dinner' relationship in behavioral ecology. Which of the following statements best describe this analogy and the relative evolutionary rates of the prey and predator species in a population?

- I. This analogy indicates the fact that the prey species serves as the 'dinner' for the predator species, the 'life' of which depends on the former.
- II. This analogy indicates that a prey species caught by a predator loses its 'life' while a predator that fails to catch a prey only loses a 'dinner'.
- III. The prey species is usually under greater selection pressure from its predators and tends to evolve faster than does a predator species.
- IV. The predator species is usually under greater selection pressure because of its dependence on a prey species for food and tends to evolve faster than does a prey species.

- a. I and III
- b. I and IV
- c. II and III
- d. II and IV

**ETHOLOGY (4 points)**

58. (1 point) Animals can use their circadian clocks to determine direction from the position of the sun. In a particular experiment conducted in Iceland, a bird, kept in a cage open to the sky, was trained to seek food on the western side. Its circadian rhythm was then phase-delayed by 6 hours and after phase shifting, the bird was returned to its open cage at 12.00 noon real time. It was observed to seek food in the:

- a. north.
- b. south.
- c. east.
- d. west.

59. (1 point) Coho Salmon is a fish found in the freshwater streams of North America. The males of this species have two reproductive strategies to fertilize the eggs laid by females. Larger males are able to fight with each other successfully but smaller males are unable to do so. The latter adopt another strategy, that of sneaking, in which they hide behind rocks and quickly approach females to fertilize the eggs before the larger males are able to do so. Which of the following graphs depicts the correct strategies?

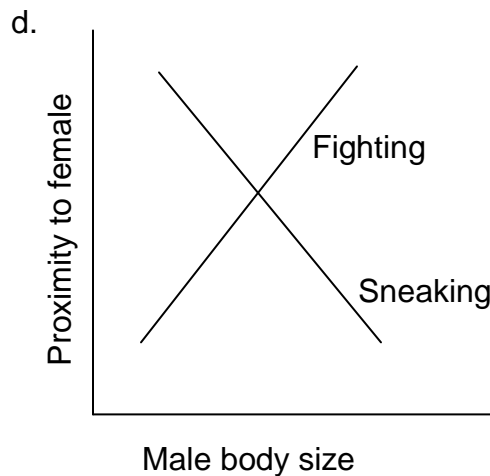
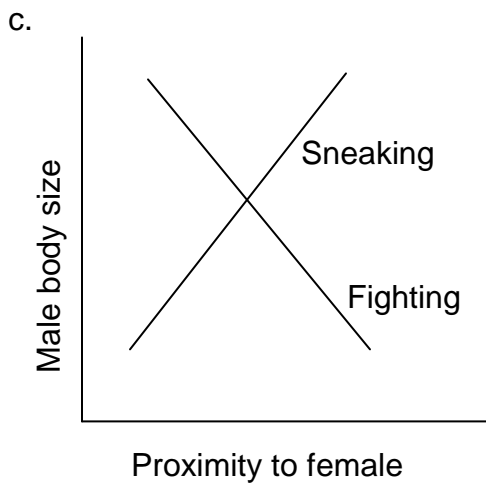
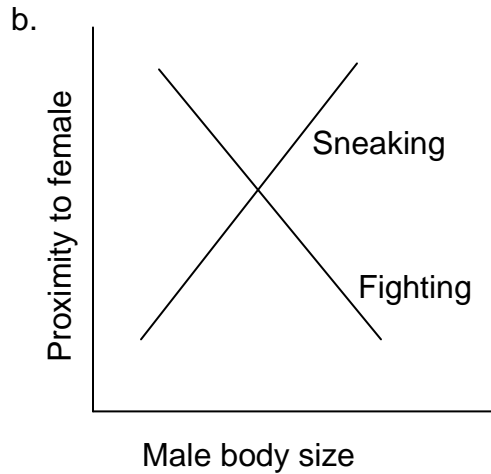
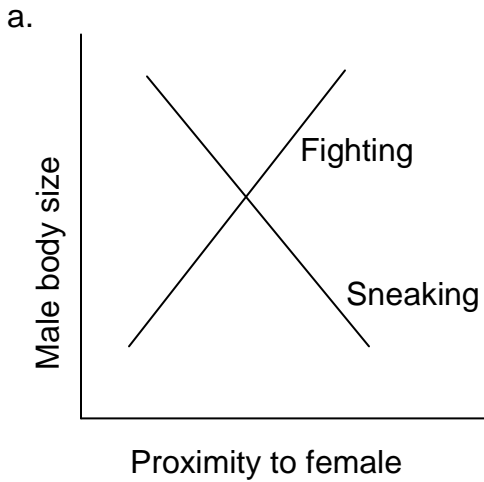

60. (1 point) Young laughing gull chicks peck at the tip of the parent's beak which, in turn, induces the adult gull to regurgitate food. Experiments were conducted with one-day old and three-day old chicks, the latter being reared with their parents. These chicks were presented with the following models of the parent head and the following responses were obtained:

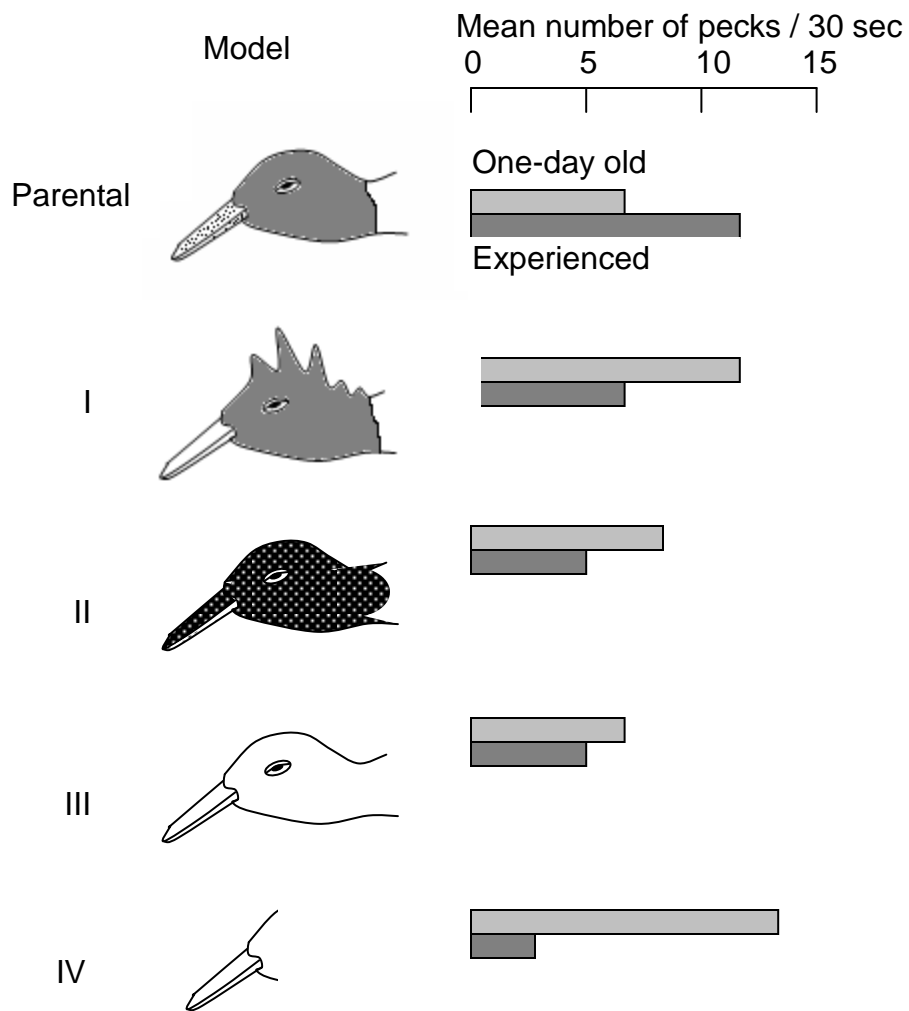

Choose the correct interpretation of the experiment.

- a. Pecking behavior is a fixed action pattern where any long pointed object acts as an equally effective stimulus.
- b. The pecking rate of laughing gull chicks increases with age.
- c. The response of one-day old chicks is more pronounced when the model is closer to that of the parent.
- d. Act of pecking is an innate behavior while the discriminatory capacity of the chicks is a result of learning.



61. (1 point) While studying the frogs of a certain species in their natural habitat during the mating season, you observe a chorus of male frogs in which some individuals are calling while others remain silent. On further observation, you see the silent frogs are sitting closer to those that are calling.

Which of the following is most likely to explain the behavior of this chorus of frogs?

- a. The individuals who are not calling are staggering their calls with those of the others and are likely to call later in the season after the latter have finished mating.
- b. The silent frogs are close genetic relatives of the calling individuals and do not expend valuable energy in calling as the matings that the latter will receive would provide adequate indirect fitness to them.
- c. The silent frogs have evaluated that their calls are inadequate in attracting females, as compared to those of the calling individuals, and lie in wait to sneak matings with the females that approach the calling males.
- d. The silent frogs do not expend energy in themselves calling as the female frogs that are attracted to the calls of the others are anyway likely to visually inspect the closely-spaced males and then choose their mating partners.

**BIOSYSTEMATICS (2 points)**

62. (1 point) Although *Echidna* lays eggs, it has been classified as a mammal due to the presence of mammary glands. Which of the following additional features support its inclusion in the class Mammalia?

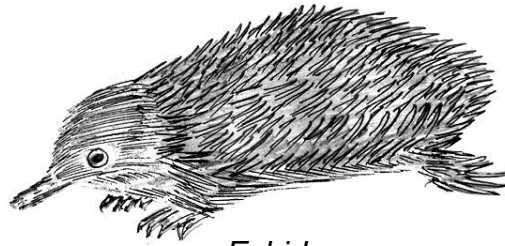

*Echidna*

- I. Hair over parts of the body.
  - II. Presence of pituitary and thyroid gland.
  - III. Complete separation of pulmonary and systemic circulation in a 4 - chambered heart.
  - IV. A diaphragm separating thoracic and abdominal cavities.
  - V. Regulation of body temperature irrespective of ambient temperature.
  - VI. Enucleated red blood cells.
- 
- a. III and VI
  - b. I, IV and V
  - c. Only I and IV
  - d. I and II
  - e. I, IV and VI

63. (1 point) Study the adjoining schematically drawn evolutionary lineage. The derived characters A, B and C represent, respectively:

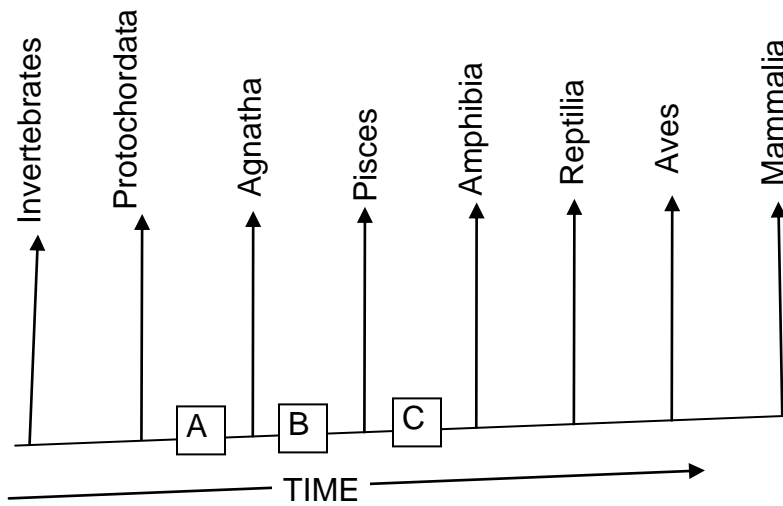

- vertebral column and cranium, jaw, lung.
- tail, heart, teeth.
- heart, gill, cranium.
- cranium, cloaca, hepatic portal system.

\*\*\*\*\* END OF PART A \*\*\*\*\*